

让世界的包装因揽德更美好

Make the world's packaging be better because LANDPACK

LANDPACK

揽德包装机械



中文官网



English Web

FILLING MACHINE CATALOG

灌装机画册



佛山市揽德包装机械有限公司

FOSHAN LAND PACKAGING MACHINERY CO.,LTD

地址：广东省佛山市南海区狮山镇下柏第一工业区吉祥路9号智晟科技产业园

Add: Zhisheng Technology Industrial Park, No. 8 Jixiang Road, Xiabai First Industrial Zone, Shishan Town, Nanhai District, Foshan, Guangdong, China

Tel: 0757-81807872 Fax: 0757-81807758

网址: www.landpack.cn Web: www.landpack.com

E-mail: yang@landpacking.com

佛山市揽德包装机械有限公司

FOSHAN LAND PACKAGING MACHINERY CO.,LTD



About LandPack

关于揽德

Foshan Land Packaging Machinery Co., Ltd. is located in Foshan, Guangdong Province, within a one-hour drive from Guangzhou Airport and just 20 minutes from Foshan High-Speed Railway Station. Established in 2017, the company is a high-tech enterprise integrating R&D, manufacturing, sales, and service. With a modern factory covering 30,000 square meters, Landpack is equipped with a team of senior engineers, installation and commissioning technicians, and marketing & after-sales service professionals. With over 130 employees, we provide customers with professional products and reliable service support.

Since its establishment, Landpack has been dedicated to the R&D and manufacturing of vertical form fill seal machines, filling machines, premade pouch packaging machines, multi lane packaging machines, flow pack machines, and feeding and packaging lines. Our products are widely applied in industries such as snacks food and health supplements, pet food, daily chemical products, fresh produce, sauces, and powders, offering customized and complete packaging solutions for enterprises.

Our products have obtained lots of national patent certificates, ISO9001 Quality Management System certification, as well as CE, TUV, SGS, and FDA approvals. They are exported to more than 100 countries and regions worldwide, receiving wide recognition and praise from customers.

At Landpack, we are committed to continuously refining and optimizing our products to deliver intelligent packaging equipment that is efficient, stable, safe, and beautiful packaging—striving to go beyond expectations and make the world a better place with Landpack Packaging.

佛山市揽德包装机械有限公司坐落于广东省佛山市，位于广州机场一小时，佛山动车站二十分钟交通圈。公司成立于2017年，是一家集研发、制造、销售及服务于一体的高新技术企业，配备三万平米现代化厂房，拥有骨干工程师，安装调试技术团队和营销与售后技术服务团队，员工规模达130人，为客户提供专业的产品和服务保障。

我司自成立以来，专注于研发和制造立式包装机，灌装机，给袋式包装机，多列机和枕式机、理料线包装设备，产品广泛用于休闲零食食品、食品保健品，宠物食品，日用化工用品，果蔬生鲜，酱料和粉剂等行业，致力为企业客户定制和提供整体包装解决方案。

产品已获多个国家技术专利证书，并通过ISO9001质量管理体系认证，获欧盟CE, TUV, SGS, FDA认证。产品远销海外一百多个国家和地区，受到企业客户广泛好评和认可。

揽德人将持续深耕和优化产品，为客户提供高效、稳定、安全、包装美观的智能包装设备，并力求超越，让世界因揽德包装而更美好。



Development History of LandPack

揽德发展历程

2017-2018

Established 成立

LANDPACK brand was established, independently developed and manufactured vertical machines and pillow machines, obtained ISO9001 quality management system certification, EU CE, TUV, SGS, FDA certification, and its products were exported to more than 60 countries and regions, and has been widely praised and recognized by corporate customers.

LANDPACK揽德品牌建立，自主研发生产制造立式机和枕式机，获ISO9001质量管理体系认证，欧盟CE, TUV, SGS, FDA认证，产品远销六十多个国家和地区，受到企业客户广泛好评和认可。

2019-2024

Expansion 壮大

The Landpack's factory has expanded to 10,000 square meters, establishing dedicated departments for premade pouch machines, multilane packaging machines, and filling machines, along with a supporting machining center. The team has grown with the addition of senior engineers, experienced installation and commissioning technicians, as well as marketing and after-sales professionals, bringing the workforce to 140 employees. Our sales team has actively promoted the LANDPACK brand by participating in major exhibitions in Germany, Thailand, and across China, including Shanghai and Qingdao. Drawing on deep expertise in packaging solutions for snacks, pet food, daily chemical products, health supplements, and pharmaceuticals, the company delivers over 180 customized full-line packaging solutions annually, achieving a turnover of 80 million RMB.

厂房规模扩大至一万平方米，建立给袋机产品部门，多列机产品部门和灌装机产品部门，并建立配套机加工中心，新增多名骨干工程，资深安装调试技术员，营销和售后技术人员，员工规模达140人，继销售团队参加海外德国展、泰国展，及国内上海、青岛等多个展会进行品牌营销。结合公司团队深耕积累休闲零食食品，宠物食品，日用化工，保健品药品行业包装技术方案经验。一年为客户定制提供180多个整线包装方案，公司营业额达8000万。

2025-NOW

Development 发展

After thorough preparation, the company officially relocated from its 10,000m² old factory to a new 30,000m² modern plant. The expanded space accommodates more production lines and R&D areas, not only meeting the growing demand for capacity but also providing employees with an enhanced working environment. This relocation marks more than a physical upgrade—it represents a new milestone for high-quality development, empowering LANDPACK to serve customers with stronger capabilities and move forward with greater momentum.

历经筹备，公司正式从1万方旧厂房，乔迁至3万方新址！新厂房空间扩容，可承载更多生产线与研发区域，既解产能增长之需，也为员工提供更优环境。这不仅是物理空间的升级，更是公司迈向高质量发展的新起点，未来将以更强实力服务客户、聚力前行。





Technical strength 技术实力



CE 认证



CE 认证



CE 认证



Rohs证书



TUV 认证

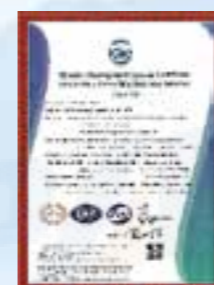

ISO 认证



SGS 认证



专利证书



专利证书



专利证书



专利证书



专利证书



专利证书



专利证书



专利证书

Sales Marketing And Technical Services

营销和技术服务



200+
Industry packaging solution cases
every year

100%
After-sales technical service support



LandPack Exhibitions

揽德展会



目/录

CONTENTS >>>>

装箱码垛方案 Box Cartoning Palletizing Packing Solutions

全自动灌装线配置装箱机械手码垛包装系统 Automatic Bottle Filling Line with Box Cartoning Palletizing Robot Packing System	P01
全自动灌装装箱码垛包装线 Automatic Container Filling Line with Cartoning Boxing Palletizing Packing System	P03

液体灌装方案 Liquid Filling Solutions

全自动活塞灌装线 Autoamtic Sauce Piston Filling Machine Line	P05
全自动酱油灌装生产线 Automatic Soybean Sauce Bottle Filling Machine Line	P07
全自动洗涤剂齿轮泵灌装生产线 Automatic Gear Pump Detergent Filling Machine Line	P08
全自动移动跟踪灌装生产线 Automatic Movable Honey/jam Filling Machine Line	P09
全自动直流灌装机生产线 Automatic Gravity Filling Machine Line	P10
全自动果汁灌装线 Autoamtic Juice Liquid Filling Machine Line	P11
全自动醋调味料灌装线 Autoamtic Vinegar Seasoning Liquid Filling Machine Line	P12
大桶全自动称重灌装生产线 Automatic Weighing Liquid Filling Production Line	P13
全自动活塞式灌装机 Full Automatic Piston Filling Machine	P14
自流式液体灌装机 Self-flowing Liquid Filling Machine	P15
齿轮泵灌装机 Gear Pump Filling Machine	P16
移动跟踪齿轮泵灌装机 Movable Gear Pump Filling Machine	P17
简易款齿轮泵灌装机 Simple Gear Pump Filling Machine	P18
6头壶嘴袋圆盘灌装旋盖一体机灌装机 6 Heads Spout Pouch Filling Machine	P19

颗粒灌装方案 Granule Filling Solutions

坚果颗粒全自动灌装包装线 Automatic Filling Production Line For Granules Dried	P20
坚果颗粒全自动灌装生产线(桶装) Automatic Filling Production Line For Granules Dried(Container Package)	P21
线性秤颗粒灌装生产线 Linear Scale Granule Filling Production Line	P22
谷物颗粒全自动灌装生产线 Automatic Filling Production Line For Grains	P23
小颗粒全自动灌装生产线 Automatic Filling Production Line For Tiny Granules	P24
颗粒+液体全自动灌装生产线 Automatic Filling Production Line For Granules+Liquid	P25
五金钉子装箱灌装生产线 Automatic Hardware Filling Line	P27
组合秤颗粒灌装机 Combined Scale Particle Filling Machine	P28
量杯式灌装机 Measuring Cup Filling Machine	P29
线性秤灌装机 Linear Scale Filling Machine	P30

粉末灌装方案 Powder Filling Solutions

全自动双头粉末灌装线 Automatic Double Heads Powder Filling Line	P31
粉末全自动灌装生产线 Automatic Powder Filling Production Line	P33
单头粉剂灌装线 Automatic Single Head Powder Filling Line	P34
全自动转盘连续式高速粉末灌装线 Automatic High Speed Rotary Continuous Powder Filling Line	P35
全自动双头转盘式粉末灌装线 Automatic Double Heads Rotary Powder Filling Line	P36
三头粉剂灌装线 Automatic Three Heads Powder Filling Line	P37
粉末自动灌装机 Automatic Double Heads Powder Filling Machine	P38
单头粉剂自动灌装机 Automatic Single Head Powder Filling Machine	P39
半自动粉末灌装机 Semi-automatic Screw Filling Machine	P40

封尾机方案 Tube Filling Machine Solutions

全自动高速封尾机灌装封口包装线 Automatic High Speed Tube Filling Sealing Packing Line	P41
塑料软管全自动封尾机 Automatic Plastic Tubes Filling And Sealing Machine	P42
全自动塑料软管灌装封口机(带冷水机) Automatic Plastic Tube Filling Sealing Machine With Water Chiller	P43
金属封折尾机 Metal Sealing And Folding Machine	P44

Automatic Bottle Filling Line with Box Cartoning Palletizing Robot Packing System

全自动灌装线配置装箱机械手码垛包装系统

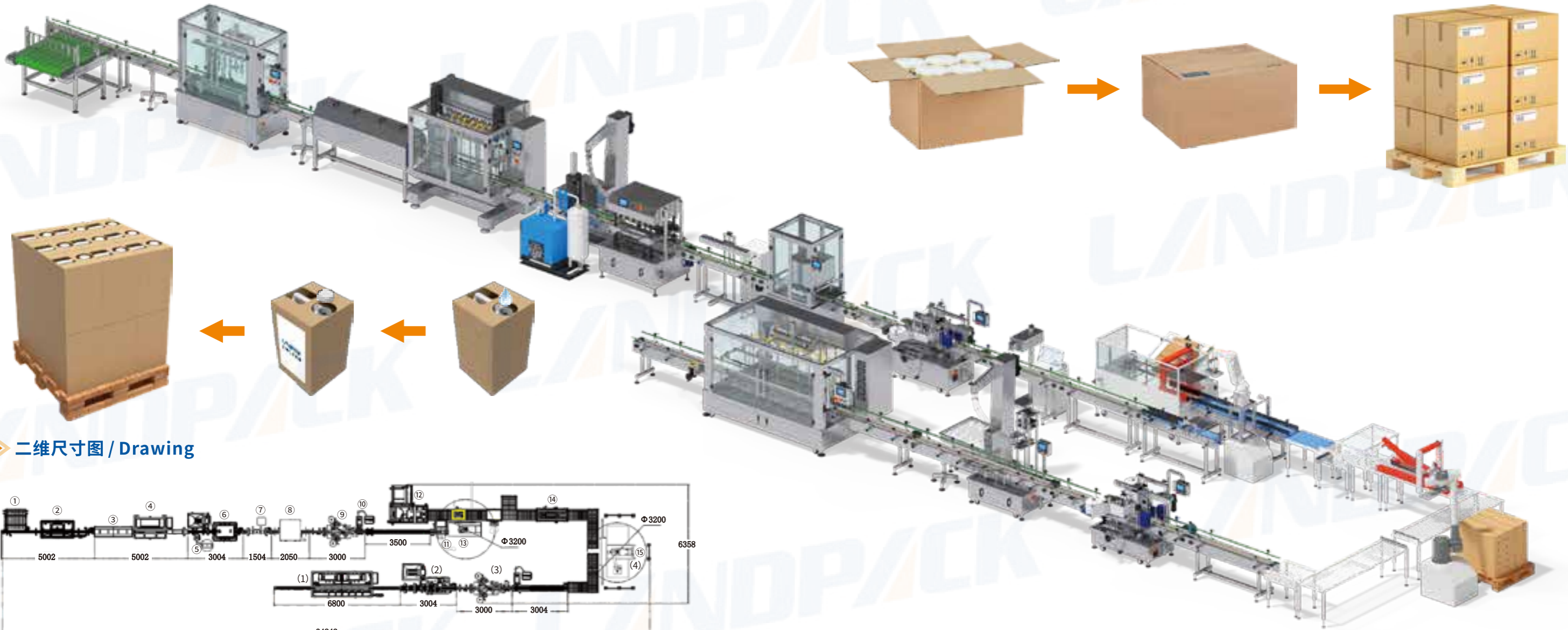

二维尺寸图 / Drawing

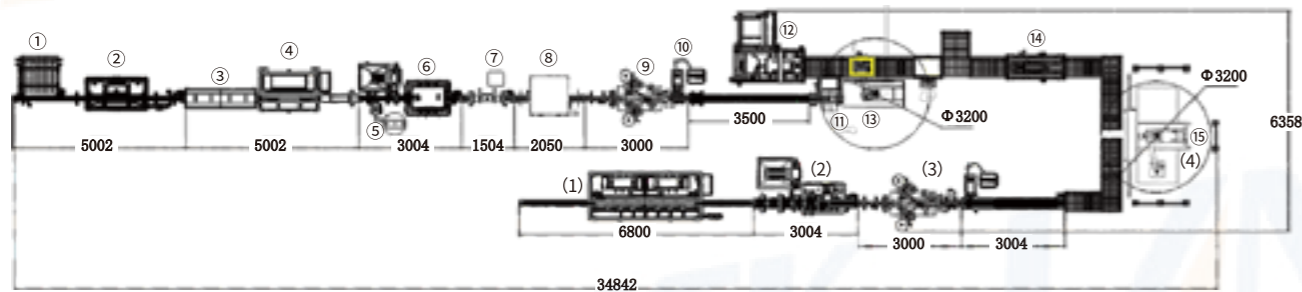

配套机组 (1)	①皮带进瓶+②负离子洗瓶机+③紫外线杀菌通道+④6头齿轮泵灌装机+⑤液氮加注机+⑥高速旋盖机+⑦风冷铝箔封口机+⑧全自动封罐机+⑨双面贴标机+⑩喷码机+⑪集料平台+⑫开箱机+⑬协作型装箱机器人+⑭封箱机+⑮码垛工业机器人
Machine Name (1)	①Bottler Feeder+②Negative Ions Air Blow Bottle Washing Machine+③UV Light Sterilizer+④6 Heads Gear Pump Filling Machine+⑤Liquid Nitrogen Filling Machine+⑥High Speed Capping Machine+⑦Foil Sealing Machine+⑧Vacuum Seamer Machine+⑨Double Side Labeling Machine+⑩Inkjet Printer+⑪Collecting Table+⑫Box Opening And Sealing Machine+⑬Carton Manipulator+⑭Auto Box Closing And Sealing Machine+⑮Palletizing Robot
配套机组 (2)	(1)6头大桶称重灌装机+(2)伺服旋盖机+(3)双面贴标机+(4)码垛工业机器人
Machine Name (2)	(1)6 Head Weighing Filling Machine+(2)Servo Capping Machine+(3)Double Side Labeling Machine+(4)Palletizing Robot

特点 / Characteristic

1	全自动灌装装箱码垛生产线, 最大程度自动化, 提高生产力	Fully automatic filling, packing and palletizing production line, with maximum automation and improved productivity.
2	机器由成熟的PLC系统和触摸屏控制, 工人可以简单灵活地使用和操控机器。	The whole set of machine is controlled by the touch screen and PLC controlling system, so it is very easy for the worker to operate the machine well.
3	高速旋盖机, 速度快而且调节盖子尺寸十分简单便捷;	High-speed capping machine, fast speed and easy to adjust the cap size;
4	码垛工业机器人, 适用于多种垛型, 承重能力高且工作覆盖区域广。	Palletizing industrial robot, suitable for various types of pallets, with high load-bearing capacity and wide working area coverage.

Automatic Container Filling Line with Cartoning Boxing Palletizing Packing System

全自动灌装装箱码垛包装线

>> 特点 /Characteristic

1	高度自动化,提升效率 全自动流程设计,减少人工干预,生产速度更快,稳定性更高。模块化组合,可根据需求灵活调整设备配置,适应不同产品类型(粉末、酱料、液体、颗粒等)	High Automation,Enhanced Efficiency Fully automated process minimizes manual intervention, ensuring faster and more stable production. Modular design allows flexible configuration to handle different products (powder, paste, liquid, granules, etc.).
2	精准灌装,保障质量 高精度灌装系统,确保每瓶重量/体积一致,误差 $\leq \pm 1\%$ 。金属检测仪实时监测,杜绝异物混入,符合食品安全标准。	Precise Filling,Guaranteed Quality High-accuracy filling system ensures consistent weight/volume per bottle (tolerance $\leq \pm 1\%$) Metal detector provides real-time inspection to eliminate contaminants, meeting food safety standards.
3	多功能一体化 覆盖完整包装流程:理瓶→清洗→灌装→旋盖→封口→贴标→装箱→码垛,一站式完成。双头灌装设计(粉末&酱料),提升产能,适合大批量生产。	Multi-functional integration End-to-end packaging process: Unscrambling → Washing → Filling → Capping → Sealing → Labeling → Case Packing → Palletizing, all in one line. Dual-head filling (powder & paste) boosts output, ideal for mass production.
4	稳定可靠,易于维护 优质不锈钢材质,耐腐蚀、易清洁,符合GMP/HACCP要求。智能控制系统,故障自动报警,操作简便,维护成本低。	Reliable & Easy Maintenance High-grade stainless steel construction, corrosion-resistant and easy to clean, compliant with GMP/HACCP. Smart control system with auto-alert for faults, user-friendly operation, and low maintenance costs.
5	智能化与可扩展性 兼容多种包装规格(瓶型、箱型),切换快速,减少停机时间。	Smart & Scalable Adaptable to various packaging sizes (bottles, boxes), quick changeover reduces downtime.

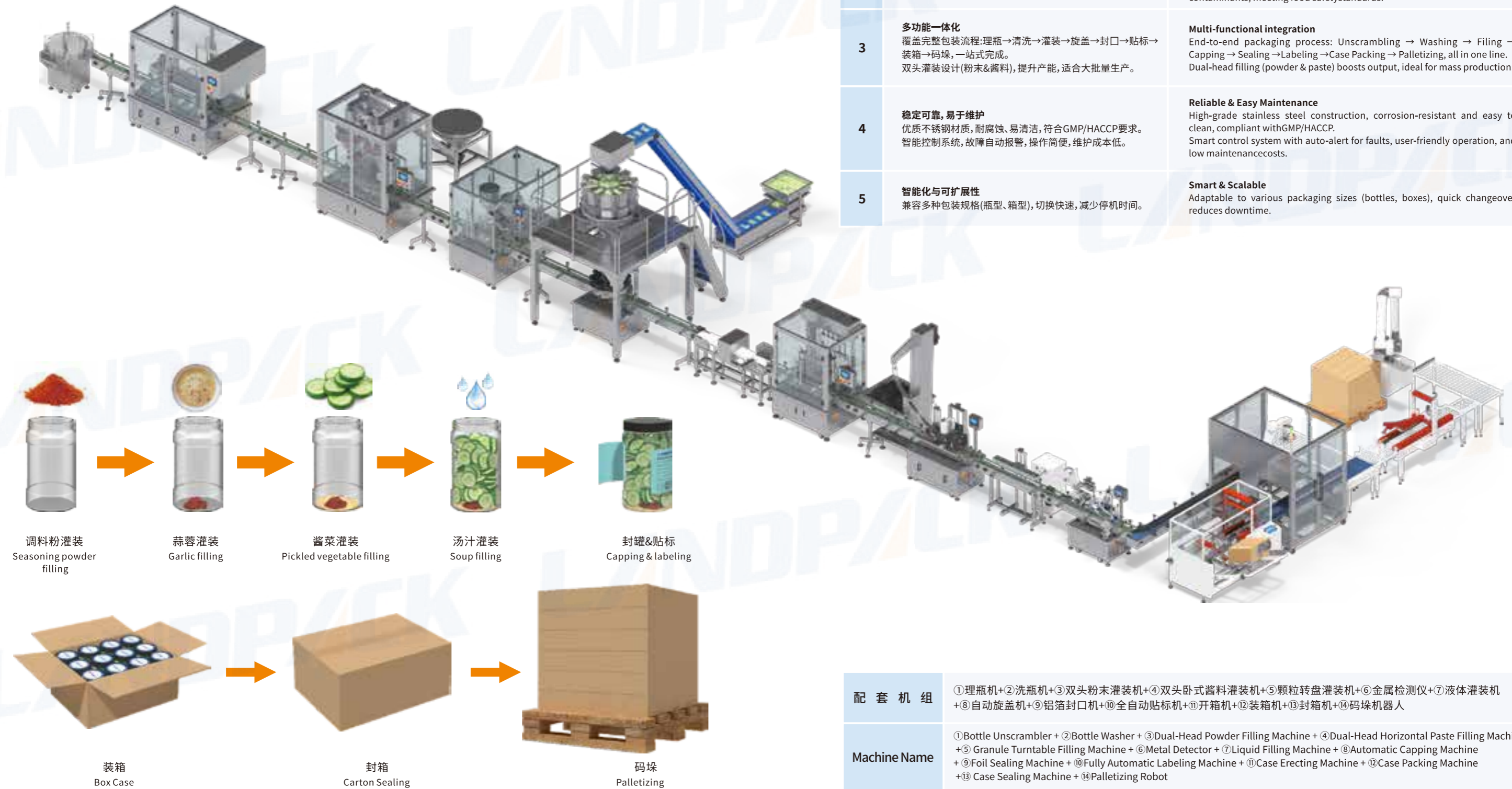

配套机组	①理瓶机+②洗瓶机+③双头粉末灌装机+④双头卧式酱料灌装机+⑤颗粒转盘灌装机+⑥金属检测仪+⑦液体灌装机+⑧自动旋盖机+⑨铝箔封口机+⑩全自动贴标机+⑪开箱机+⑫装箱机+⑬封箱机+⑭码垛机器人
Machine Name	①Bottle Unscrambler + ②Bottle Washer + ③Dual-Head Powder Filling Machine + ④Dual-Head Horizontal Paste Filling Machine + ⑤ Granule Turntable Filling Machine + ⑥Metal Detector + ⑦Liquid Filling Machine + ⑧Automatic Capping Machine + ⑨Foil Sealing Machine + ⑩Fully Automatic Labeling Machine + ⑪Case Erecting Machine + ⑫Case Packing Machine + ⑬ Case Sealing Machine + ⑭Palletizing Robot

Autoamtic Sauce Piston Filling Machine Line

全自动活塞灌装线



>> 二维尺寸图 / Drawing

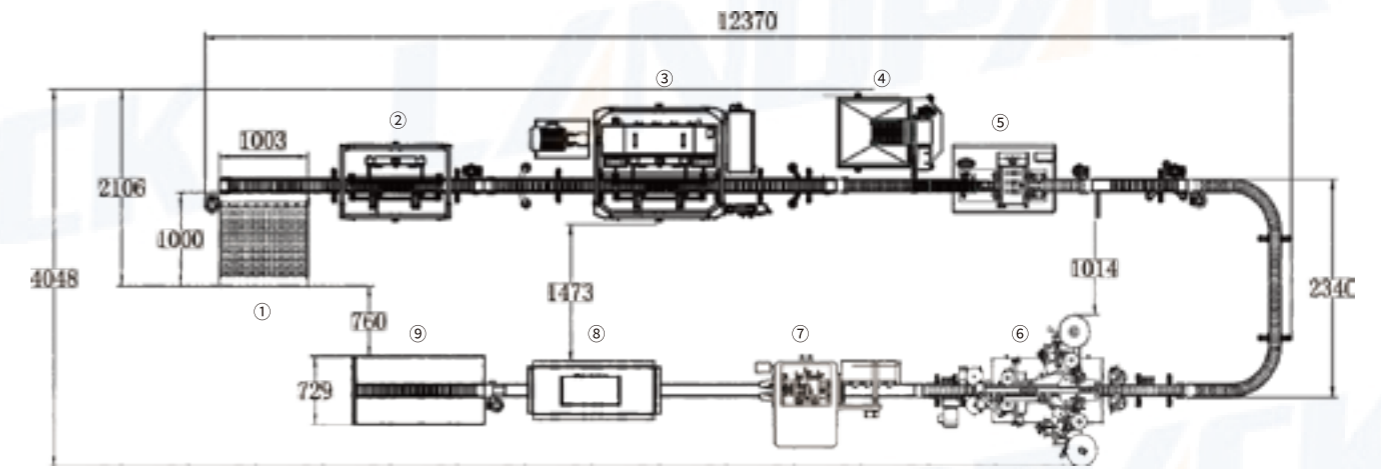

配套机组	①理瓶机+②4头负离子洗瓶机+③4头活塞灌装机+④提升上盖机+⑤四轮旋盖机+⑥双面贴标机+⑦套标机+⑧电热收缩机+⑨收集平台+⑩半自动封箱机
Machine Name	① Bottle Feeder+② Negative Ion Bottle Washing Machine+③ 4 Heads Piston Filling Machine+④ Caps Feeder+⑤ Screw Capping Machine+⑥ Double Side Labeling Machine+⑦ Sleeve Labeling Machine+⑧ Shrink Labeling Machine+⑨ Collecting Table+⑩ Semi-Automatic Carton Sealing Machine

>> 适用物料 / Application



>> 样品 / Sample



>> 特点 / Characteristic

1	采用世界知名品牌的电器和气动元件, 故障率低, 性能可靠, 使用寿命长; Adopts world-famous brands of electrical and pneumatic components, low failure rate, reliable performance, long service life;
2	与物料接触均为不锈钢制作, 拆装简便, 易清洗, 符合GMP要求; Material contact parts are made of stainless steel, easy to disassemble and assemble, easy to clean and meet the requirements of GMP.
3	灌装量和灌装速度调整简单, 由触摸屏操作和显示, 外形美观; Easy to adjust filling volume and filling speed, operated and displayed by touchscreen, beautiful appearance.
4	设有无瓶不灌装功能, 液位自动控制加料; With no bottle no filling function, liquid level automatic control feeding;
5	不需更换零件, 即可快速调整各种不同形状规格的瓶子; No need to change any parts, you can quickly adjust the various specifications of the shape of the bottle;
6	灌装头设有特殊防漏装置, 灌装绝无拉丝, 滴漏现象。 The filling head is equipped with a special leak-proof device. No wire drawing or drip leakage occurs during filling.

Automatic Soybean Sauce Bottle Filling Machine Line 全自动酱油灌装生产线



>> 二维尺寸图 / Drawing

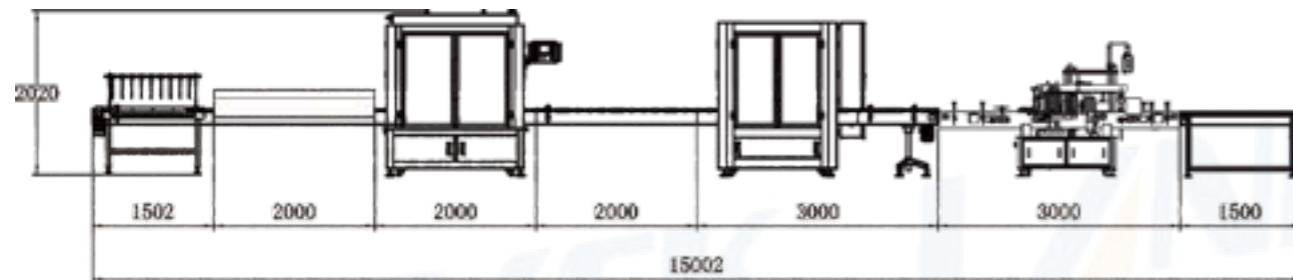
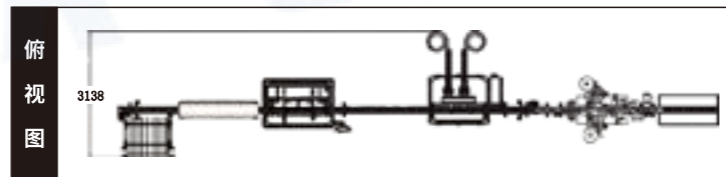

配套机组	①皮带进瓶+②紫外线杀菌通道+③10头齿轮泵灌装+④2头移动旋盖机+⑤风冷铝箔封口机+⑥双面贴标机+⑦收集平台
Machine Name	①Bottler Feeder+② UV Light Sterilizer+③10 Heads Gear Pump Filling Machine With Vacuum Suction+④2 Heads Movable Capping Machine+⑤Aluminum Foil Sealing Machine+⑥Double Side Labeling Machine+⑦Collecting Table

>> 样品 / Sample



>> 特点 / Characteristic

1	直线机适合所有类型的瓶子。更换不同尺寸的瓶子时，不需要更换任何零件，只需调整机器即可；	The linear machine suits for all kind of bottle. It could be don't need to change any spear part when you change different size bottle,just adjust the machine.
2	机器由成熟的PLC系统和触摸屏控制，工人可以简单灵活地使用和操控机器；	The whole set of machine is controlled by the touch screen and PLC controlling system, so it is very easy for the worker to operate the machine well.
3	移动旋盖机，可识别瓶子跟踪式旋盖，可增加旋盖速度；	Movable capping machine can identify the bottle and track the capping, which can increase the capping speed;
4	酱油容易起泡沫，需加装带真空吸料功能的灌装头（适合带泡沫的酱油液体灌装），以及带加热功能的料斗。	Soy sauce foams easily, so you need to add filling heads with vacuum suction function.(Suitable for soy liquid filling with foam),and Hopper with heating funtion.

Automatic Gear Pump Detergent Filling Machine Line 全自动洗涤剂齿轮泵灌装生产线



>> 二维尺寸图 / Drawing

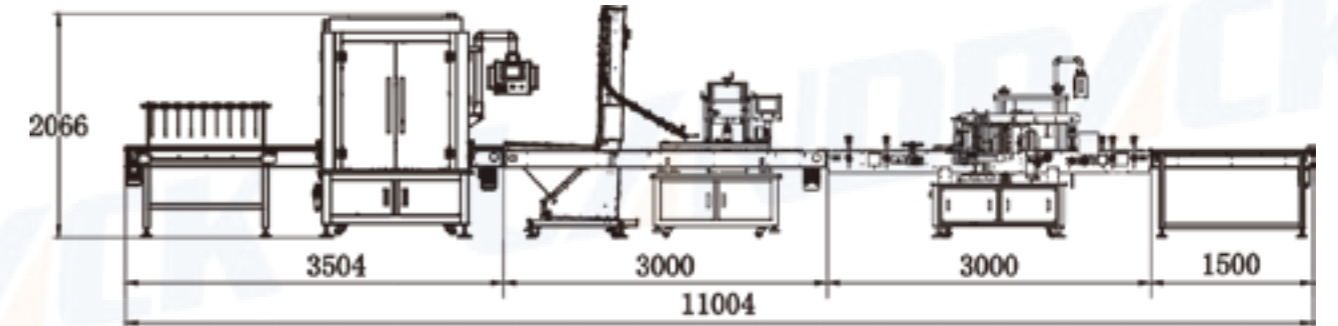

配套机组	①皮带理瓶机+②6头齿轮泵灌装+③提升上盖机+④四轮旋盖机+⑤双面贴标机+⑥收集平台
Machine Name	①Bottle Feeder+②6 Heads Gear Pump Filling Machine+③Caps Feeder+④Screw Capping Machine+⑤Double Side Labeling Machine+⑥Collecting Table

>> 样品 / Sample



>> 特点 / Characteristic

1	定制送瓶装置，适用于圆瓶或方形瓶	Square bottle feeder to feed round bottle or square bottle;
2	灌装头：齿轮泵灌装系统，由伺服电机控制，确保高计量精度，灌装范围不受限制，适用于洗涤剂/油/酱汁液体等	Filling machine:Gear pump filling system, which is controlled by servo motor to ensure the high metering precision and has no limited filling range.suitable for detergent/ oil/sauce liquid ect;
3	提升上盖机：适合多种盖子类型，不同盖子只需更换导轨	Lifting cap machine:suitable for a variety of cap types, different covers only need to replace the guide rail;
4	四轮旋盖机：适用于不同尺寸的盖子，当您更换不同尺寸的盖子时，您不需要更换任何部件，只需要调整机器。	Screw capping machine:suitable for different size cap,when you change different size cap you don't need to change any spear part,only need to adjust the machine.
5	双面贴标机：适用于圆瓶、方瓶单面贴标或双面贴标。	Double sides labeling machine:which is suitable for round bottle and square bottle labeling with one side label or two side label.
6	收集平台用于收集成品	The collection platform is used to collect finished products

Automatic Movable Honey/jam Filling Machine Line

全自动移动跟踪灌装生产线



二维尺寸图 / Drawing

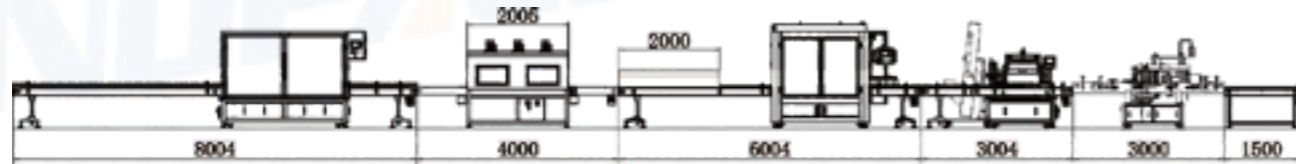

配套机组	①翻转式洗瓶机+②烘干机+③紫外线杀菌通道+④4头移动活塞灌装+⑤提升上盖机+⑥双头四轮旋盖机+⑦双面贴标机+⑧收集平台
Machine Name	①Flip-Type Bottle Washing Machine+②Dryer+③2m UV Light Sterilizer+④4 Heads Movable Piston Filling Machine+⑤Caps Feeder+⑥Two Heads Screw Capping Machine+⑦Double Side Labeling Machine+⑧Collecting Table

样品 / Sample



特点 / Characteristic

1	<p>翻转式洗瓶机:</p> <p>有两种清洗方式:水洗和气洗,玻璃瓶水洗,塑料瓶气洗;</p> <p>◆机器连接水源时为水洗,连接气源时为气洗。</p> <p>◆选择玻璃瓶水洗时,建议同时配备烘干消毒装置。</p>	<p>Flip-type washing machine:</p> <p>Have two type washing,Water and air washing,Water washing for glass bottle,Air washing for plastic bottle;</p> <p>◆When the machine is connected to the water source, it is Water washing, and when it is connected to the air source, it is Air washing.</p> <p>◆When you choose the water washing for glass bottle,then it's better to equip with dryer Sterilization together.</p>
2	<p>四头移动式活塞灌装</p> <p>◆活塞式灌装方式,适用于糖浆、果酱和蜂蜜等液体;</p> <p>◆可灌装100-1000毫升,灌装200毫升时约60次/分,灌装1000毫升时约45-50次/分。(取决于物料液体、瓶子尺寸和灌装范围);</p> <p>◆传感器,一旦夹紧瓶颈,瓶口追上瓶子,就会向PLC发出信号,控制物料灌装。如果追上瓶颈失败,则不会灌装。即无瓶不灌装。</p>	<p>4 heads movable piston filling machine</p> <p>◆Piston filling way,can suitable for Syrup, jam and honey liquid;</p> <p>◆Can filling 100-1000ml,about 60bpm when fill 200ml,about 45-50bpm when fill 1000ml.(depends on the material liquid and bottle size and filling range);</p> <p>◆Sensor, Once clamp bottle necks catch up bottles then it will give signal to the PLC to filling material. If catch up bottle neck failed then will not filling. So it means no bottle no filling function</p>
3	<p>双面贴标机:适用于圆瓶、方瓶单面贴标或双面贴标。</p>	<p>Double sides labeling machine:which is suitable for round bottle and square bottle labeling with one side label or two side label.</p>

Automatic Gravity Filling Machine Line

全自动直流灌装机生产线



二维尺寸图 / Drawing

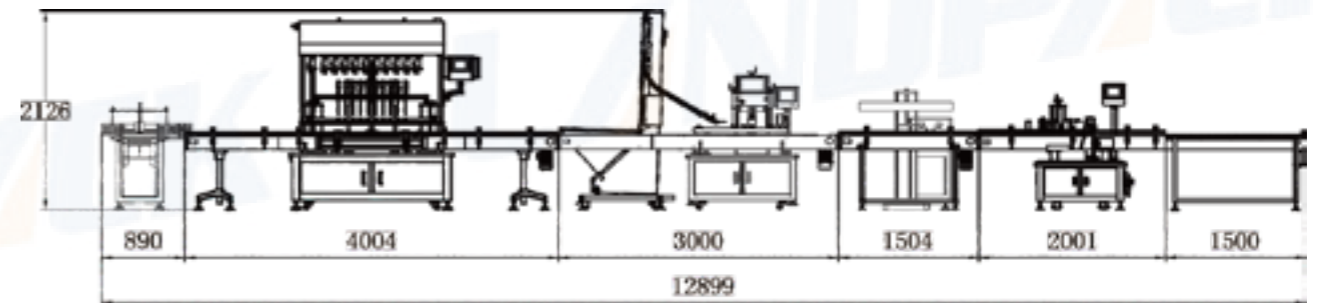

配套机组	①理瓶机+②8头自流灌装机+③提升上盖机+④四轮旋盖机+⑤铝箔封口机+⑥圆瓶贴标机+⑦收集平台
Machine Name	①Bottle Feeder+②8 Heads Gravity Filling Machine+③Caps Feeder+④Screw Capping Machine+⑤Aluminum Foil Sealing Machine+⑥Round Bottle Labeling Machine+⑦Collecting Table

样品 / Sample



特点 / Characteristic

1	<p>灌装范围和速度可依据用户需求来设计不同的灌装头数;</p>	<p>The filling range and speed can be designed with different filling heads according to user needs;</p>
2	<p>灌装采用固定流道参数,控制灌装时间来实现不同计量的灌装。气动阀灌装的精准时间可设定到0.01秒,能使计量精度控制±1%误差范围,减少不必要的物料损耗。</p>	<p>The filling adopts fixed flow channel parameters to control the filling time to achieve filling with different measurements. The precise time of pneumatic valve filling can be set to 0.01 seconds, which can control the measurement accuracy within the error range of ±1% and reduce unnecessary material loss.</p>
3	<p>适合流动性比较好的液体,比如水,油,农药等液体</p>	<p>Suitable for liquids with good fluidity, such as water, oil, pesticides, etc.</p>

Autoamtic Juice Liquid Filling Machine Line

全自动果汁灌装线



>> 二维尺寸图 / Drawing

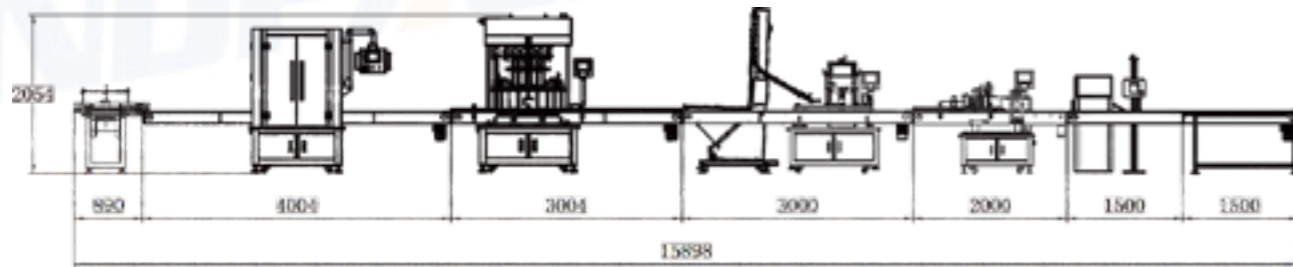

配套机组	①理瓶机+②负离子洗瓶机+③6头活塞灌装机+④提升上盖机+⑤四轮旋盖机+⑥圆瓶贴标机+⑦喷码机+⑧收集平台
Machine Name	① Bottle Feeder+② Negative Ion Bottle Washing Machine+③ 6 Heads Piston Filling Machine+④ Caps Feeder+⑤ Screw Capping Machine+⑥ Round Bottle Labeling Machine+⑦ Inkjet Printer+⑧ Collecting Table

>> 样品 / Sample



>> 特点 / Characteristic

1	触摸屏式操作界面;	Touch screen operation interface;
2	料仓有加热搅拌功能,能使液体均匀灌装进瓶;	Hopper with heating and stirring functions, which can make the liquid evenly filled into the bottle;
3	充填精度可达±1%;	The filling accuracy can reach ±1%;
4	充填缸研磨处理,独特的充填阀设计,不滴漏;	The filling cylinder is ground, unique filling valve design, no leakage;
5	附无瓶不灌装,积瓶自动停机功能;	With no bottle no filling and automatic bottle stop function;
6	根据瓶子的实际情况设计不同的定位装置;	Design different positioning devices according to the actual situation of the bottle;
7	设备清洗方便,可无工具拆装,亦可在线清洗或高温灭菌;	The equipment is easy to clean, can be disassembled without tools, it can also be cleaned online or high temperature sterilization;
8	设备接触物料材质采用SUS304不锈钢;	Material contact parts are made of SUS304 stainless steel;
9	设备符合卫生,安全标准,用户可以选择玻璃防护罩。	The equipment meets the hygiene and safety standards. The user can choose the glass protective cover.

Autoamtic Vinegar Seasoning Liquid Filling Machine Line

全自动醋调味料灌装线



>> 二维尺寸图 / Drawing

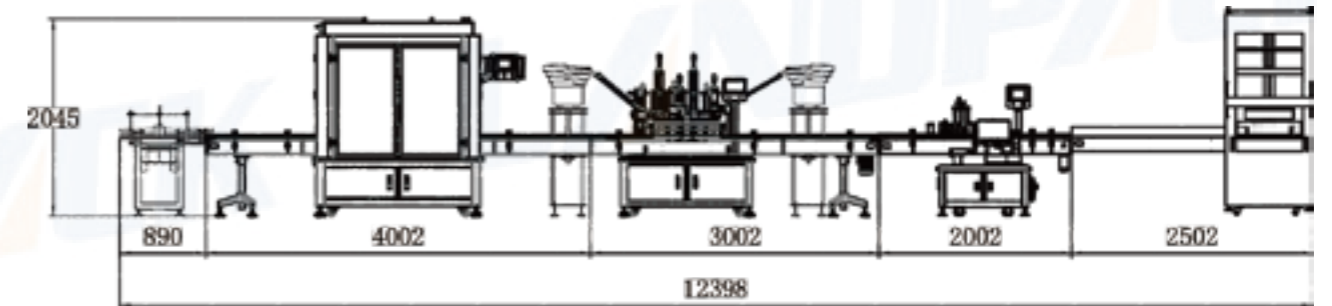

配套机组	①10头齿轮泵灌装线+②振动盘上盖+③自动桶盖机+④高速贴标机+⑤侧入式套膜机+收缩机+⑥收集平台
Machine Name	① 10 Hedges Gear Pump Filling Machine+② Vibration Plate Cap Feeder+③ Autoamtic Capping Machine+④ High Speed Round Bottle Labeling Machine+⑤ Side-Entry Sleeve Shrink Machine+Shrink Wrapping Machine+⑥ Collection Table

>> 样品 / Sample



>> 特点 / Characteristic

1	电眼自动检测瓶子,无瓶不灌装;	Sensors are used to detect the position of the bottle, no bottle, no filling.
2	整机使用304不锈钢材质,利用振动盘理盖,上盖;	The whole machine is made of stainless steel and uses vibrating bowls to automatically sort the caps.
3	使用圆瓶定位贴标机,贴标精准不起皱;	Use round bottle positioning labeling machine to label accurately without wrinkles.
4	节约更多的时间和人力成本	Save more labors and time.
5	可以灌装的液体产品,比如水,果汁,食用油,芝麻油等无颗粒的液体产品	This full automatic 10-head filling line can be used to fill liquid products such as water, juice, edible oil, sesame oil and other liquid products without particles.

Automatic Weighing Liquid Filling Production Line 大桶全自动称重灌装生产线



>> 二维尺寸图 / Drawing

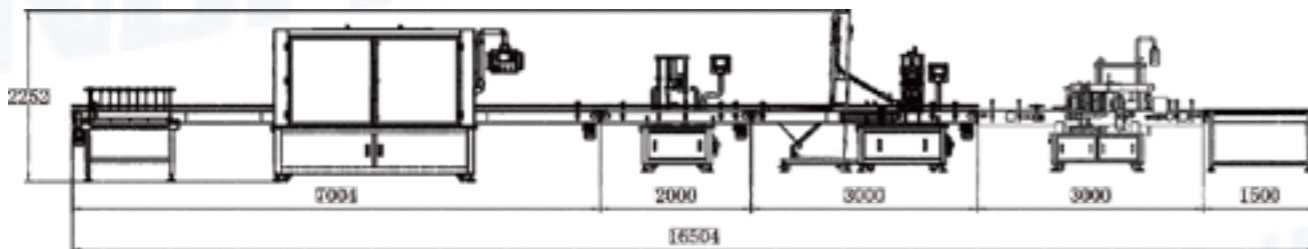

配套机组	①进瓶皮带+②大桶称重灌装机+③振动盘上盖+④桶盖机+⑤提升上盖机+⑥伺服旋盖机+⑦双面贴标机+⑧收集平台
Machine Name	① Bottle Feeding Belt+② Liquid Weighing Filling Machine+③ Vibration Plate+ ④ Inner Cap Pressing Machine +⑤ Caps Feeder+⑥ Servo Capping Machine+⑦ Bottle Labeling Machine+⑧ Collecting Table

>> 样品 / Sample



>> 特点 / Characteristic

1	可根据需要选配不同配置的全自动设备进行组装；	According to the needs of different configuration of automatic equipment assembly;
2	所有机器结构均是按照食品卫生标准选用设计的；	All the machine structures are selected and designed according to the food hygiene standards;
3	与物料接触的容器内壁均抛光处理；	The inner wall of the container in contact with the material is polished;
4	经常拆洗的结构都采用了易拆件连接，方便清洁卫生；	The structures that are often disassembled and washed are alconnected by easily disassembled parts,which is convenient for cleaning;
5	包装线主要适用于各种液体、流体、膏体状物料的包装，如果汁、食用油、酱料、化工品、液体化肥等；	The packing line is mainly suitable for packing all kinds of liquid,fluid and paste materials,such as juice,edible oil,sauce, Chemicals, liquid fertilizers,etc;

Full Automatic Piston Filling Machine 全自动活塞式灌装机

>> 适用物料 / Application



>> 二维尺寸图 / Drawing

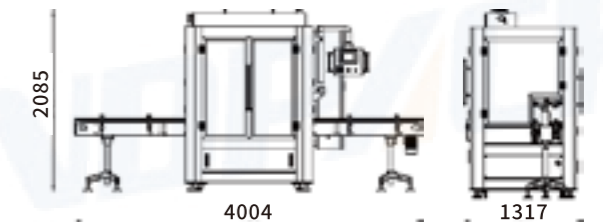

全自动伺服活塞灌装机，采用伺服控制灌装容量，精度高，调节方便。进口PLC 配合触摸屏人机界面，设备运行稳定，操作简便。适用于各种酱料，带果粒的饮料等，是食品，日化，医药，农药等各个行业的理想灌装设备。

Fully automatic servo piston filling machine, using servo control to fill capacity, accurate and easy to adjust. Imported PLC combined with touch screen human-machine interface ensures stable operation and easy operation of the equipment. Suitable for various sauces, beverages with fruit granules, etc., it is an ideal filling equipment for various industries such as food, daily chemical, pharmaceutical, pesticide, etc.

>> 样品 / Sample



>> 技术参数 / Technical parameter

型号 (Model)	LFH-04	LFH-06	LFH-08	LFH-10
灌装范围 (Filling range)	50-1000ml (customize)	50-1000ml (customize)	50-1000ml (customize)	50-1000ml (customize)
灌装速度 (Speed)	16-24 瓶/分 BPM	24-36 瓶/分 BPM	32-48 瓶/分 BPM	40-55 瓶/分BPM
计量精确度 (Accuracy)	±0.5~1%	±0.5~1%	±0.5~1%	±0.5~1%
功率 (Power)	2KW	3KW	3.5KW	3.8KW
工作电源 (Voltage)	220V, 50Hz	220V, 50Hz	220V, 50Hz	220V, 50Hz
工作气压 (Air pressure)	0.6-0.8Mpa	0.6-0.8Mpa	0.6-0.8Mpa	0.6-0.8Mpa
重量 (Weight)	600kg	650kg	750kg	800kg
机器尺寸 (Machine size)L*W*H	L4000*W1320*H2090	L4000*W1320*H2090	L4000*W1320*H2090	L4000*W1320*H2090

Self-flowing Liquid Filling Machine

自流式液体灌装机

>> 适用物料/Application



>> 二维尺寸图 / Drawing

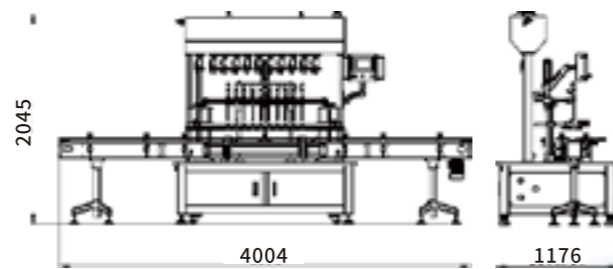

适用于各种流动性好的液体,如牛奶,食用油、纯果汁,刹车油等。灌装量参数式调节控制,非常简便精准,灌装头可根据客户的产量需求来定制。

Suitable for various liquids with good fluidity, such as milk, edible oil, pure fruit juice, brake oil, etc. Parameter based adjustment and control of filling volume, very simple and accurate, filling nozzle is customized according to your requirement.

>> 样品/Sample



>> 技术参数/Technical parameter

型号(Model)	LFZ-06	LFZ-08	LFZ-10	LFZ-12
灌装范围(Filling range)	50-1000ml (customize)	50-1000ml (customize)	50-1000ml (customize)	50-1000ml (customize)
灌装速度(Speed)	24-36 瓶/分 BPM	32-48 瓶/分 BPM	40-55 瓶/分 BPM	50-65 瓶/分 BPM
计量精确度(Accuracy)	±1%	±1%	±1%	±1%
功率(Power)	1KW	1.2KW	1.2KW	1.5KW
工作电源(Voltage)	220V, 50Hz	220V, 50Hz	220V, 50Hz	220V, 50Hz
工作气压(Air pressure)	0.6-0.8MPa	0.6-0.8MPa	0.6-0.8MPa	0.6-0.8MPa
重量(Weight)	400kg	450kg	500kg	550kg

Gear Pump Filling Machine

齿轮泵灌装机

>> 适用物料/Application



>> 二维尺寸图 / Drawing

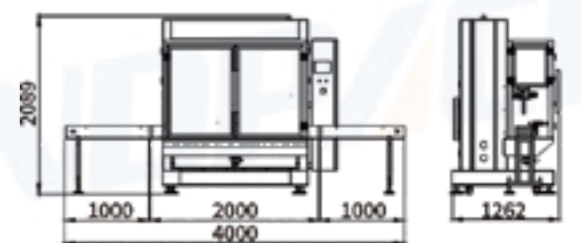

>> 特点/Characteristic

1	直线式结构,操作简便,清洁方便;	Simple structure in linear type, easy to operate and clean.
2	采用流动灌装方式,灌装精准稳定,适用于粘稠物料;	Flow filling method, accurate and stable, suitable for thick material.
3	灌装头数和速度可定制,无瓶不灌装;	Filling heads and speed can be customized. No bottle no filling.
4	可用于灌装不同容量和形状的容器,无需额外更换零件;	Can be used for filling containers of different capacities and shapes without the need for additional replacement parts.
5	可与旋盖贴标生产线连接;	It can be connected with capping labeling machine production line.
6	整机主体采用304不锈钢材质;	The whole machine main SS 304.
7	料斗混合和加热装置需定制。	Hopper mixing and heating device need to be customized.

>> 技术参数/Technical parameter

型号(Model)	LFYT-CLB-4	LFYT-CLB-6	LFYT-CLB-8	LFYT-CLB-10
灌装范围(Filling range)	50-1000ml (customize)	50-1000ml (customize)	50-1000ml (customize)	50-1000ml (customize)
灌装速度(Speed)	16-24 瓶/分 BPM	24-36 瓶/分 BPM	32-48 瓶/分 BPM	40-60 瓶/分 BPM
计量精确度(Accuracy)	±0.5~1%	±0.5~1%	±0.5~1%	±0.5~1%
功率(Power)	3.5KW	5KW	6.5KW	8KW
工作电源(Voltage)	220V, 50Hz	220V, 50Hz	220V, 50Hz	220V, 50Hz
工作气压(Air pressure)	0.6-0.8MPa	0.6-0.8MPa	0.6-0.8MPa	0.6-0.8MPa
耗气量(Gas consumption)	0.09m ³ /min	0.11m ³ /min	0.13m ³ /min	0.15m ³ /min
重量(Weight)	400kg	450kg	500kg	550kg

Movable Gear Pump Filling Machine

移动跟踪齿轮泵灌装机



>> 样品/Sample



>> 二维尺寸图 / Drawing

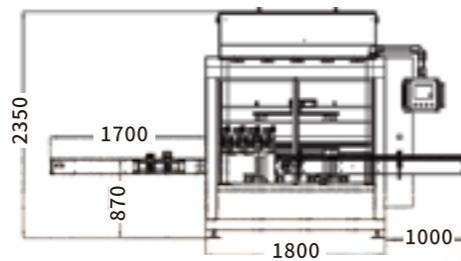

>> 特点 /Characteristic

1	高速,跟踪式移动灌装,适合高产能。	High speed,track movable track filling,it suits for high production capacity.
2	由链条输送机、夹瓶自动对位机构、灌装机构、伺服自动跟随系统、电动升降调节机构、防水电控柜、触摸式人机界面等组成。	Operated by chain conveyor, bottle clamping automatic alignment mechanism, filling mechanism, automatic servo following system, electric lifting adjustment mechanism, waterproof electric cabinet, touch-type man-machine Interface, etc
3	自动抓取瓶子,并通过触摸屏轻松调整。	Automatically catch the bottles and is easy to adjust by touch screen.
4	可适用于不同规格瓶子的自动灌装设备。	Can be for automatic filling equipment of bottles of different specifications.
5	广泛应用于灌装粘稠液体,如蜂蜜、面霜、机油、洗发水、日化用品等液体产品。	Widely used in filling viscous liquids,such as honey,cream,engine oil ,shampoo,daily chemicals and other liquid products.

>> 技术参数 /Technical parameter

型号(Model)	LFZ-02	LFZ-04	LFZ-06	LFZ-08	LFZ-10
灌装范围(Filling range)	50-1000ml (customize)				
灌装速度(Speed)	20-40 瓶/分 BPM	40-60 瓶/分 BPM	60-80 瓶/分 BPM	80-100 瓶/分 BPM	100-120瓶/分 BPM
计量精确度(Accuracy)	±1%	±1%	±1%	±1%	±1%
功率(Power)	3.5KW	5KW	6.5KW	20KW	20KW
工作电源(Voltage)	220V, 50Hz	220V, 50Hz	220V, 50Hz	220V, 50Hz	220V, 50Hz
工作气压(Air pressure)	0.6-0.8MPa	0.6-0.8MPa	0.6-0.8Mpa	0.6-0.8Mpa	0.6-0.8Mpa
重量(Weight)	400kg	450kg	550kg	600kg	650kg

Simple Gear Pump Filling Machine

简易款齿轮泵灌装机



>> 适用物料 /Application



>> 二维尺寸图 / Drawing

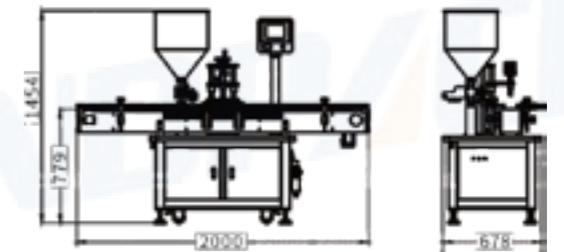

>> 样品/Sample



>> 特点 /Characteristic

1	针对于膏状乳液和流动性差的物料	Especially for paste emulsions and materials with poor fluidity
2	适合小计量,不会滴漏不会拉丝	Suitable for small filling capacity.No dripping, no drawing
3	易清洗,高精度,由伺服电机控制	Easy to clean, high accuracy,servo motor controlled

>> 技术参数 /Technical parameter

型号(Model)	LFZ-01		LFZ-02	
灌装范围(Filling range)	0-100ml(customize)	50-1000ml (customize)	0-100ml(customize)	50-1000ml (customize)
灌装速度(Speed)	≤60瓶/分 BPM	≤20瓶/分 BPM	≤100瓶/分 BPM	≤40瓶/分 BPM
计量精确度(Accuracy)	±1%	±1%	±1%	±1%
功率(Power)	1.5KW	1.5KW	2.25KW	2.25KW
工作电源(Voltage)	220V, 50Hz	220V, 50Hz	220V, 50Hz	220V, 50Hz
工作气压(Air pressure)	0.6-0.8Mpa	0.6-0.8Mpa	0.6-0.8Mpa	0.6-0.8Mpa
重量(Weight)	200kg	200kg	250kg	250kg

6 Heads Spout Pouch Filling Machine 6头壶嘴袋圆盘灌装旋盖一体机灌装机



特点/Characteristic

1	灌装、旋盖全自动完成,节省人工,提升产能。	Integrated design combines filling and capping, reducing labor costs and boosting productivity.
2	高精度流量计/伺服系统,误差≤±1%,适用于多种液体(如酱料、饮品)。	Precision filling control with ±1% accuracy, adaptable to viscous or thin liquids.(E.g. sauce,drinking ect)
3	可清洗喷嘴外部,确保包装清洁卫生;	Washing the outer of spout to ensure package clean and hygienic.
4	接触部件采用304不锈钢,符合GMP/HACCP标准;	Food-grade 304 stainless steel, compliant with GMP/HACCP.
5	触摸屏PLC控制,参数可视化,操作简单。	User-friendly PLC touchscreen for intuitive parameter setting.

技术参数/Technical parameter

型号 (Model)	LD-820L
灌装头数 (Filling heads)	6
容量 (Capacity)	4000-5000袋/时 BPH(400ml)
灌装量 (Filling volume)	50-1000ml(customizable 1L 2L 3L)
误差 (Error)	≤1%
功率 (Power)	380V
气压 (Air pressure)	0.7 m ³ /min
重量 (Weight)	1200kg

Automatic Filling Production Line For Granules Dried 坚果颗粒全自动灌装包装线



二维尺寸图 / Drawing

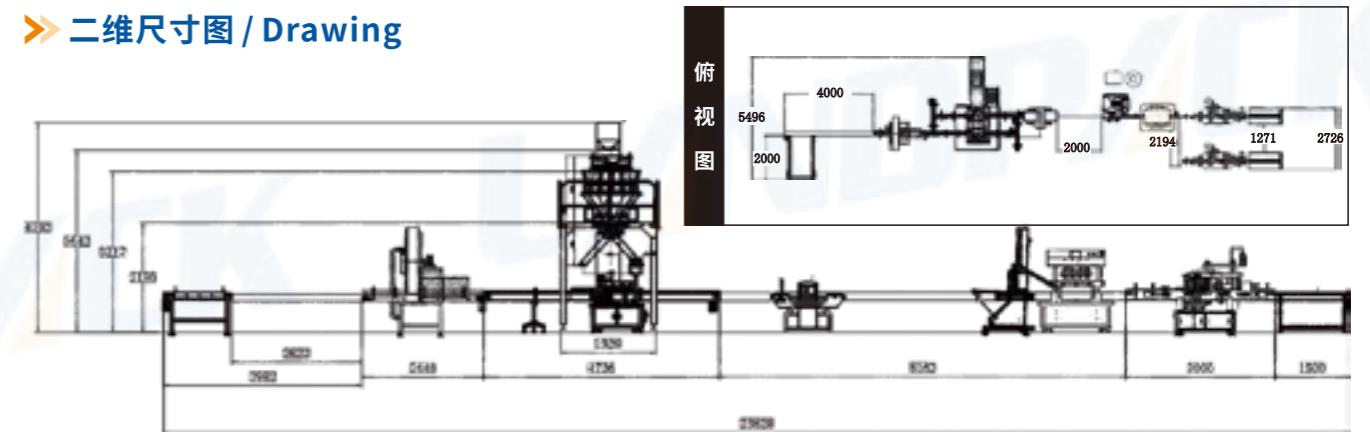

配套机组	①理瓶机+②UV紫外线杀菌机+③颗粒灌装机(Z型提升机+多头组合称+平台+双转盘颗粒灌装机)+④金属检测仪+⑤上盖机+⑥高速旋盖机+⑦铝箔电磁感应封口机+⑧双面贴标机+⑨收集平台
Machine Name	①Bottle Feeder+②UV Sterilization +③Granules Filling Machine(Z Type Material Lifting Feeder+Multi-Head Weigher +Support Platform+Dual Rotary Table Granules Filling Machine)+④Metal Detector+⑤Caps Feeding Elevator +⑥High Speed Capping Machine+⑦Foil Sealing Machine + ⑧Two Sides Labeling Machine+⑨Bottle Collecting Table

样品 / Sample



特点/Characteristic

1	可根据需要选配不同配置的全自动设备进行组装;	According to the needs of different configuration of automatic equipment assembly;
2	所有机器结构均是按照食品卫生标准选用设计的;	All the machine structures are selected and designed according to the food hygiene standards;
3	与物料接触的容器内壁均抛光处理;	The inner wall of the container in contact with the material is polished;
4	经常拆洗的结构都采用了易拆件连接,方便清洁卫生;	The structures that are often disassembled and washed are alconnected by easily disassembled parts,which is convenient for cleaning;
5	适合坚果、干果、瓜子、种子、果干,零食,糖果等颗粒装,片状,短棒状等物料的定量称量;	Suitable for quantitative weighing of nuts, dried fruits, melon seeds, seeds, dried fruits, snacks, candies and other granular, flake, short stick and other materials.

Automatic Filling Production Line For Granules Dried 坚果颗粒全自动灌装生产线(桶装) (Container Package)



二维尺寸图 / Drawing

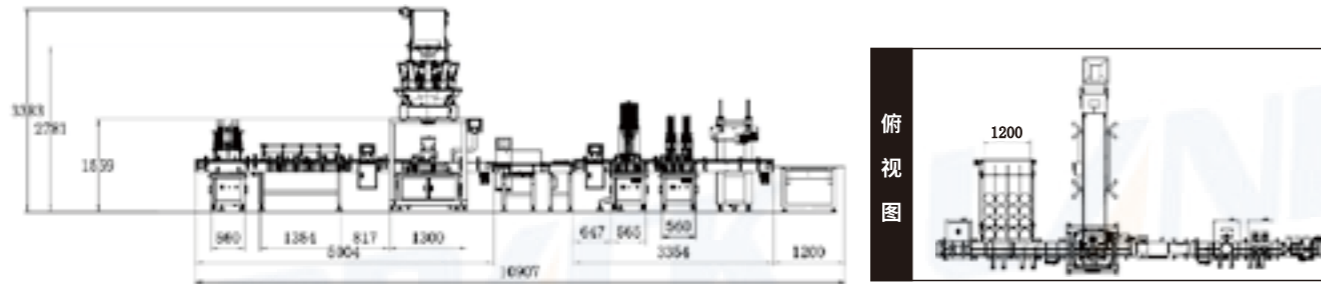

配套机组	①自动下盒机构+②皮带进盒+③颗粒灌装(裙边皮带提升机+电子秤+平台+转盘式灌装)+④重量检测仪(选配)+⑤自动下盖机构1+⑥自动下盖机构2+⑦链板压盖机+⑧收集圆盘转盘
Machine Name	① Box Auto Feeder+② Box Flat Feeding Belt+ ③ Granules Filling Machine(Skirt Type Material Feeding Conveyor +Multi Heads Weigher+Platform+Rotary Filler)+④ Checkweigher (Option)+⑤ Lids Feeder 1+⑥ Lids Feeder 2 +⑦ Lids Pressing Machine+⑧ Collecting Turntable

样品 / Sample



特点 / Characteristic

1	可根据需要选配不同配置的全自动设备进行组装;	According to the needs of different configuration of automatic equipment assembly;
2	所有机器结构均是按照食品卫生标准选用设计的;	All the machine structures are selected and designed according to the food hygiene standards;
3	与物料接触的容器内壁均抛光处理;	The inner wall of the container in contact with the material is polished;
4	经常拆洗的结构都采用了易拆件连接,方便清洁卫生;	The structures that are often disassembled and washed are alconnected by easily disassembled parts,which is convenient for cleaning;
5	包装线主要适用于各种颗粒状和固体物料的包装,如坚果果脯,中药材,锅巴,大米等;	The packing line is mainly suitable for packing all kinds of granular and solid materials,such as nuts,preserved fruits,Chinese medicinal materials,Guoba,rice,etc;

Linear Scale Granule Filling Production Line 线性秤颗粒灌装生产线



二维尺寸图 / Drawing

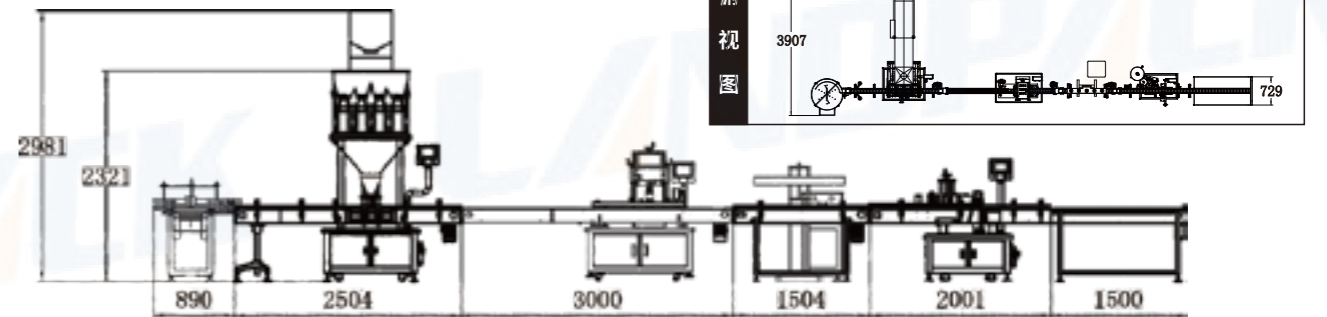

配套机组	①理瓶机+②颗粒灌装(Z型提升机+4头线性秤+颗粒灌装)+③旋盖机+④铝箔电磁感应封口机+⑤贴标机+⑥收集平台
Machine Name	①Bottle Feeder+②Granules Filling Machine(Z Type Material Lifting Feeder+4 Heads Linear Weigher +Granules Filling Machine)+③Capping+④Foil Sealing Machine+⑤Labeling Machine+⑥Bottle Collecting Table

样品 / Sample



特点 / Characteristic

1	定制型灌装称重一体机,自动化程度高,节省人工成本;	Customized filling and weighing machine, high degree of automation, save labor costs;
2	适用于颗粒状和固体物料的灌装,精度高;	It is suitable for filling granular and solid materials with high precision;
3	集料斗可调节物料灌装多少,使用方便;	The hopper can adjust the filling amount of materials, so it is easy to use;

技术参数 / Technical parameter

灌装量 (Filling weight)	20~2000g	料斗容量 (Weigher volume)	3000ml
称重精度 (Accuracy)	±1~3g	物料设置 (Material adjust)	20
灌装速度 (Speed)	10~25罐/分钟BPM	功率 (Power)	3KW
瓶子直径 (Bottle diameter)	30-150mm	电源 (Voltage)	AC220V 50/60HZ

Automatic Filling Production Line For Grains

谷物颗粒全自动灌装生产线



>> 二维尺寸图 / Drawing

>> 样品 / Sample

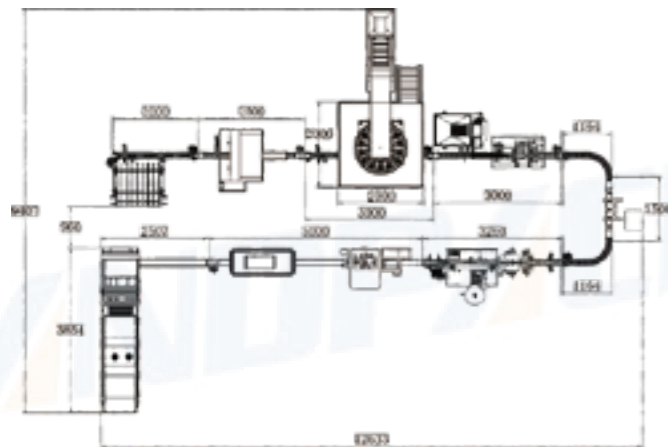

配套机组	①进瓶皮带+②UV紫外线杀菌机+③颗粒灌装机(Z型提升机+多头组合称+平台+直线式颗粒灌装机)+④上盖机+⑤四轮旋盖机+⑥铝箔电磁感应封口机+⑦贴标机+⑧套标机+⑨收缩炉+⑩自动袖口套膜机
Machine Name	①Bottle Feeding Belt+②UV Sterilization+③Granules Filling Machine(Z Type Material Lifting Conveyor +Multi-Head Weigher+Support Platform+Line Type Granules Filling Machine)+④Caps Feeding Elevator +⑤4 Wheels Capping Machine+⑥Foil Sealing Machine+⑦Labeling+⑧ Sleeve Label Machine +⑨Heating Oven+⑩Automatic Sleeve Shrink Wrapping Machine

>> 特点 / Characteristic

1	可根据需要选配不同配置的全自动设备进行组装;	According to the needs of different configuration of automatic equipment assembly;
2	所有机器结构均是按照食品卫生标准选用设计的;	All the machine structures are selected and designed according to the food hygiene standards;
3	与物料接触的容器内壁均抛光处理;	The inner wall of the container in contact with the material is polished;
4	经常拆洗的结构都采用了易拆件连接,方便清洁卫生;	The structures that are often disassembled and washed are alconnected by easily disassembled parts,which is convenient for cleaning;
5	包装线主要适用于各种颗粒状和固体物料的包装,如坚果果脯,中药材,锅巴,大米等;	The packing line is mainly suitable for packing all kinds of granular and solid materials,such as nuts,preserved fruits,Chinese medicinal materials,Guoba,rice,etc;

Automatic Filling Production Line For Tiny Granules

小颗粒全自动灌装生产线



>> 二维尺寸图 / Drawing

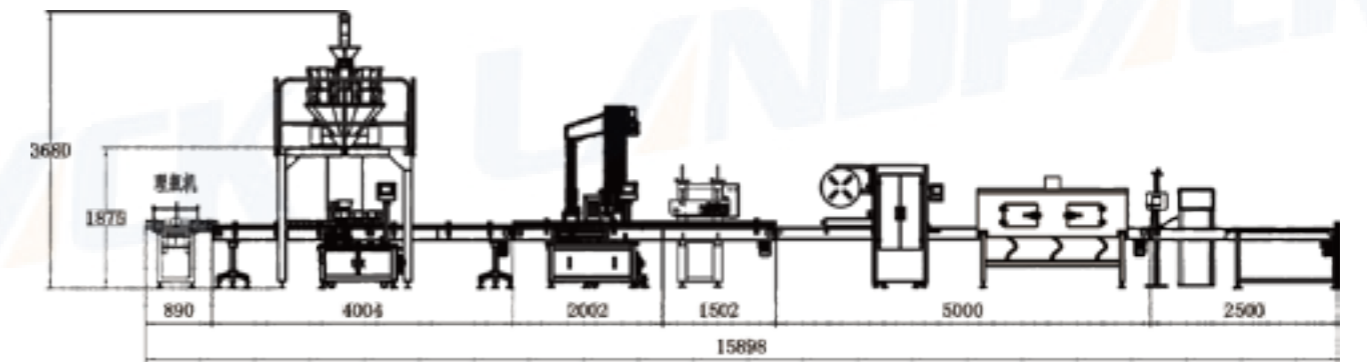

配套机组	①理瓶机+②螺杆上料机+③颗粒灌装机(多头组合称+平台+转盘式颗粒灌装机)+④全自动上盖取盖机+⑤链板压盖机+⑥全自动套标收缩机+⑦喷码机+⑧收集平台
Machine Name	①Bottle Feeder+②Auger Screw Feeding Conveyor+③Granules Filling Machine(Multi-Head Weigher +Support Platform+Rotary Filler)+④Caps Feeding Elevator+Auto Caps Placer+⑤Chain Caps Pressing Machine +⑥Labeling Sleeve Shrinking Machine+⑦Inkjet Printer+⑧Bottle Collecting Table

>> 样品 / Sample



>> 特点 / Characteristic

1	可根据需要选配不同配置的全自动设备进行组装;	According to the needs of different configuration of automatic equipment assembly;
2	所有机器结构均是按照食品卫生标准选用设计的;	All the machine structures are selected and designed according to the food hygiene standards;
3	与物料接触的容器内壁均抛光处理;	The inner wall of the container in contact with the material is polished;
4	经常拆洗的结构都采用了易拆件连接,方便清洁卫生;	The structures that are often disassembled and washed are alconnected by easily disassembled parts,which is convenient for cleaning;
5	适合盐、海盐、鸡精,调味料等小颗粒状且流动性较好的颗粒物料的定量称量;	Suitable for quantitative weighing of small granular materials with good fluidity such as salt, sea salt, chicken essence, seasonings, etc

Automatic Filling Production Line For Granules+Liquid 颗粒+液体全自动灌装生产线



二维尺寸图 / Drawing

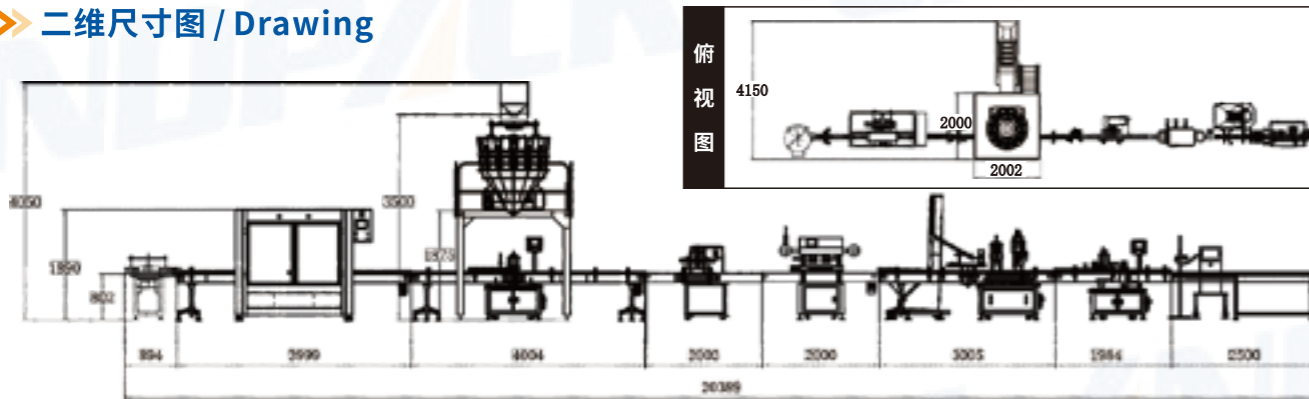

配套机组	①理瓶机+②负离子洗瓶机+③颗粒灌装(Z型提升机+多头组合称+平台)+④磁力泵液体灌装机+⑤卷膜铝箔封口机+⑥上盖机+⑦伺服旋盖机+⑧贴标机+⑨喷码机+⑩收集平台
Machine Name	①Bottle Feeder+②Bottle Washing Machine+③Granules Filling Machine(Z Type Feeding Conveyor +Multi-Head Weigher+Support Platform)+④Liquid Filling Machine+⑤Roll Foil Sealing Machine +⑥Caps Feeding Elevator+⑦Capping+⑧Labeling Machine+⑨Inkjet Printer+⑩Bottle Collecting Table

样品 / Sample



特点 / Characteristic

1	采用减速提升电机, 缺料时自动补料控制系统, 转斗式提升机构 全封闭、无污染、无泄漏, 上料, 称重, 灌装, 全程自动化控制;	Adopt decelerating lifting motor automatic feeding control system in case of material shortage, rotary bucket type lifting mechanism is fully closed, pollution-free, leakage free, feeding, weighing, filling, whole process automatic control;
2	配备国内知名超微型组合称灌装速度快, 精度高. 多语言触摸屏 人机交互系统, 可视化操作, 还能记录每一批生产的总罐数、合格率及单罐误差指标;	Equipped with domestic well-known ultra micro combination scale, the filling speed is fast and the precision is high. Multi language touch screen human-computer interaction system, visual operation, can also record each batch of production of the total number of cans, qualified rate and single can error index;
3	可额外安装剔除装置, 不符合要求重量的物料, 将会分流到另外的出口, 大大提升灌装的合格率, 避免浪费;	Additional removal device can be installed. Materials that do not meet the required weight will be diverted to another outlet, greatly improving the qualified rate of filling and avoiding waste;
4	适用于各种颗粒和固体物料混合液体类产品, 可根据物料灵活选择配置;	It is suitable for all kinds of granular and solid materials, and can be flexibly selected and configured according to the materials;
5	采用组合称下料计量, 速度更快, 精度更高	Using a combination scale for cutting and measuring, with faster speed and higher accuracy.

Automatic Filling Production Line For Granules+Liquid 颗粒+液体全自动灌装生产线



二维尺寸图 / Drawing

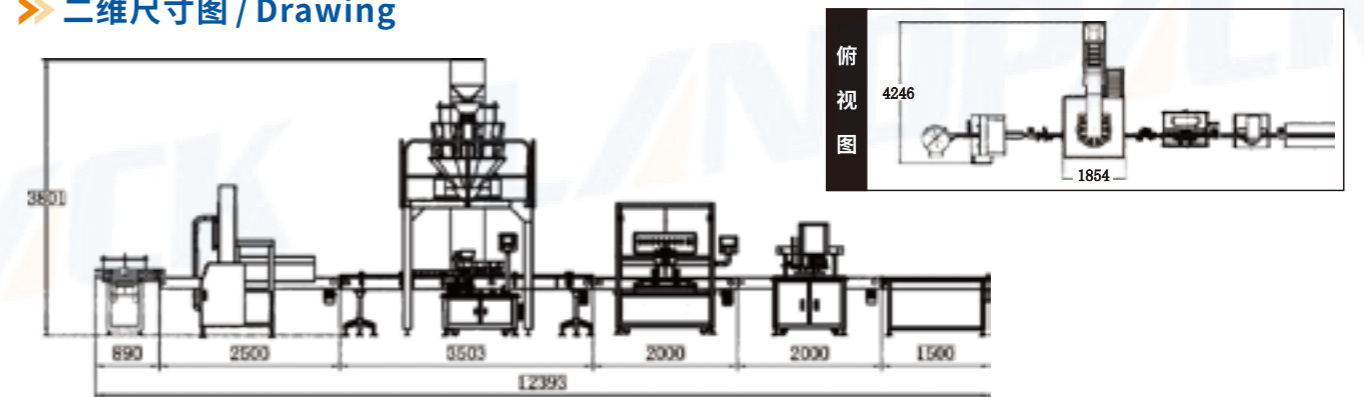

配套机组	①理瓶机+②UV紫外线杀菌机+③颗粒灌装(Z型提升机+多头组合称+平台)+④液体灌装机+⑤封罐机+⑥收集平台
Machine Name	①Bottle Feeder+②UV Sterilization +③Granules Filling Machine(Z Type Feeding Conveyor +Multi-Head Weigher +Support Platform)+④Liquid Filling Machine +⑤Can Seaming Machine+⑥Bottle Collecting Table

样品 / Sample



技术参数 / Technical parameter

型号(Model)	LD-10	LD-14
计量头数(Weighing head)	10	14
单次称重范围(Filling range)	10-1000g	10-2000g
称量精度(Accuracy)	±0.5-2g	±0.3-1.5g
称量速度(Speed)	20-30 BPM	25-35 BPM
料斗容量(Weigher volume)	1.6L	1.6L
产品预设模式(Adjustment)	99	99
瓶子直径(Bottle diameter)	30-150mm	30-150mm
瓶子高度(Bottle height)	50-220mm	50-220mm

Automatic Hardware Filling Line 五金钉子装箱灌装生产线

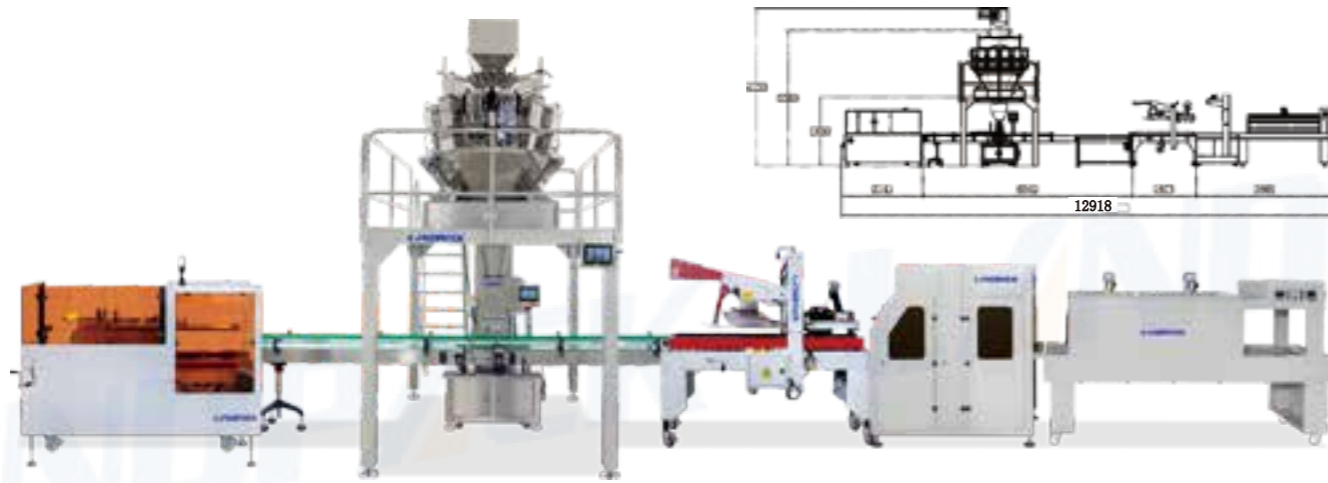

配套机组	①开箱机+②颗粒灌装机(裙边皮带提升机+多头组合称+平台+直线式颗粒灌装机)+③封箱机+④袖口套膜收缩机
Machine Name	①Carton Unpacking Machine +②Granules Filling Machine (Skirt Type Material Feeding Conveyor +Multi-Head Weigher+Support Platform+Granule Filler) +③Carton Tape Sealing Machine +④Automatic Sleeve Shrink Wrapping Machine

适用物料/Application



样品/Sample



特点/Characteristic

1	定制型灌装称重装箱封箱自动生产线,自动化程度高,节省人工成本;	Customized filling, weighing, carton filling and sealing machine, high degree of automation, save labor costs;
2	适用于单一类五金产品的灌装,精度高;如钉子,螺丝,垫片,螺母等等。	Suitable for filling a single type of hardware products with high precision; such as nails, screws, washers, nuts, etc.
3	集料斗可调节物料灌装多少,使用方便;	The hopper can adjust the filling amount of materials, so it is easy to use;
4	采用组合称下料计量,速度更快,精度更高	Using a combination scale for cutting and measuring, with faster speed and higher accuracy.

Combined Scale Particle Filling Machine 组合秤颗粒灌装机



适用物料/Application



二维尺寸图/Drawing

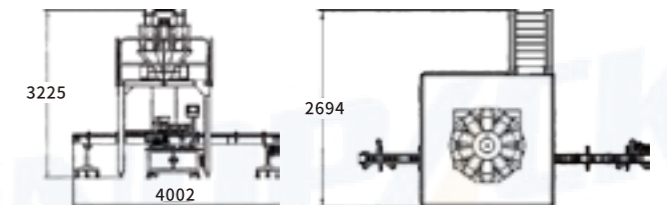

样品/Sample



特点/Characteristic

1	采用减速提升电机,缺料时自动补料控制系统,转斗式提升机构全封闭、无污染、无泄漏,上料,称重,灌装,全程自动化控制;	Adopt decelerating lifting motor, automatic feeding control system in case of material shortage, rotary bucket type lifting mechanism is fully closed, pollution-free, leakage free, feeding, weighing, filling, whole process automatic control;
2	配备国内知名超微型组合称灌装速度快,精度高。多语言触摸屏人机交互系统,可视化操作,还能记录每一批生产的总罐数、合格率及单罐误差指标;	Equipped with domestic well-known ultra micro combination scale, the filling speed is fast and the precision is high. Multi language touch screen human-computer interaction system, visual operation, can also record each batch of production of the total number of cans, qualified rate and single can error index;
3	可额外安装剔除装置,不符合要求重量的物料,将会分流到另的出口,大大提升灌装的合格率,避免浪费;	Additional removal device can be installed. Materials that do not meet the required weight will be diverted to another outlet, greatly improving the qualified rate of filling and avoiding waste;
4	适用于各种颗粒和固体物料,可根据物料灵活选择配置;	It is suitable for all kinds of granular and solid materials, and can be flexibly selected and configured according to the materials;

技术参数/Technical parameter

型号(Model)	LD-10	LD-14
计量头数(Weighing head)	10	14
单次称重范围(Filling range)	10-1000g	10-2000g
称量精度(Accuracy)	±0.5-2g	±0.3-1.5g
称量速度(Speed)	20-30 BPM	25-35 BPM
料斗容量(Weigher volume)	1.6L	1.6L
产品预设模式(Adjustment)	99	99
瓶子直径(Bottle diameter)	30-150mm	30-150mm
瓶子高度(Bottle height)	50-220mm	50-220mm

Measuring Cup Filling Machine 量杯式灌装机

二维尺寸图 / Drawing

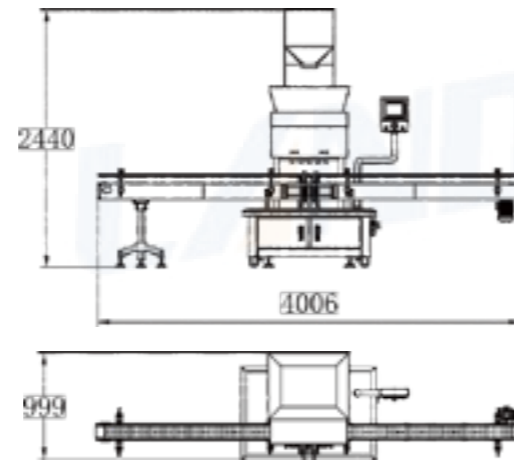

样品 / Sample



特点 / Characteristic

1	料分装, 封罐和贴标工作全部由机器自动完成;	The sub packing, sealing and labeling are all completed automatically by the machine;
2	分装过程采用特殊设计, 高出罐体的物料不会影响封罐工作;	Special design is adopted in the sub packing process, so the material higher than the tank body will not affect the sealing work;
3	适合爆米花、大米、花生、开心果等颗粒状并以容积作为主要定量指标的分装包装;	Suitable for popcorn, rice, peanut, pistachio and other granular packaging with volume as the main quantitative index;

技术参数 / Technical parameter

定量原理 (Metering way)	量杯体积 Measuring cup volume
定量范围 (Filling range)	100-1000ml
包装速度 (Speed)	10-25 Bottles/min
气源 (Air pressure)	0.6MPa

Linear Scale Filling Machine 线性秤灌装机

适用物料 / Application



二维尺寸图 / Drawing

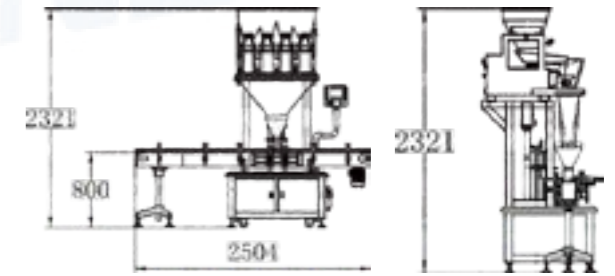

样品 / Sample



特点 / Characteristic

1	定制型灌装称重一体机, 自动化程度高, 节省人工成本;	Customized filling and weighing machine, high degree of automation, save labor costs;
2	适用于颗粒状和固体物料的灌装, 精度高;	It is suitable for filling granular and solid materials with high precision;
3	集料斗可调节物料灌装多少, 使用方便;	The hopper can adjust the filling amount of materials, so it is easy to use;

技术参数 / Technical parameter

灌装量 (Filling weight)	20~2000g	料斗容量 (Weigher volume)	3000ml
称重精度 (Accuracy)	±1~3g	物料设置 (Material adjust)	20
灌装速度 (Speed)	10~25罐/分钟BPM	功率 (Power)	3KW
瓶子直径 (Bottle diameter)	30-150mm	电源 (Voltage)	AC220V 50/60HZ

Automatic Double Heads Powder Filling Line

全自动双头粉末灌装线



二维尺寸图 / Drawing

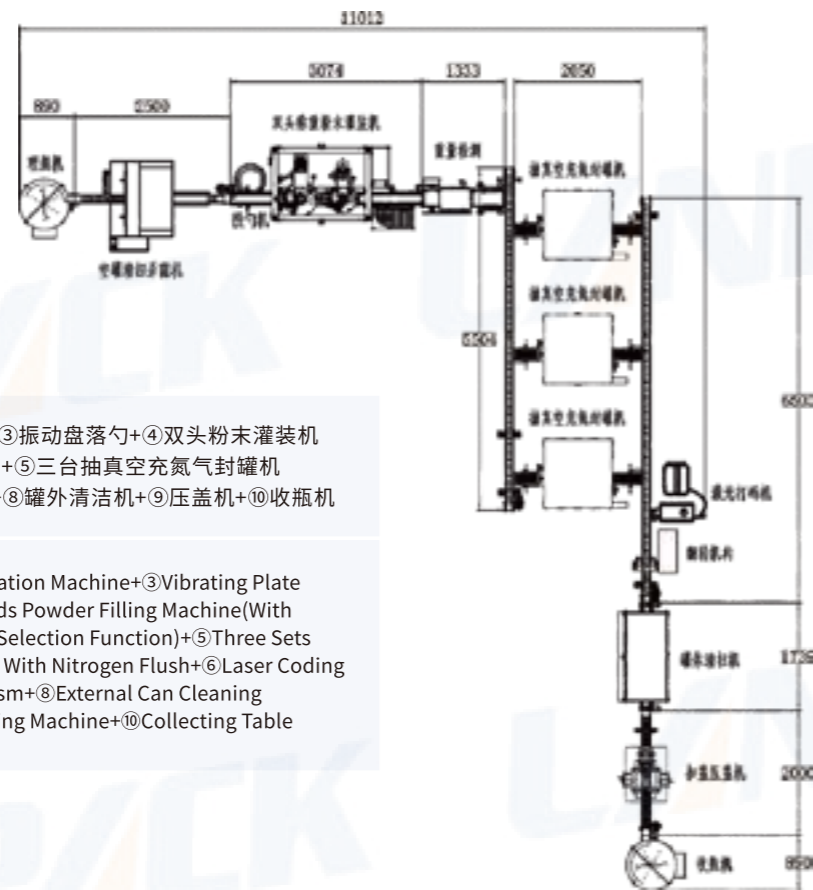

配套机组	①理瓶机+②UV紫外杀菌机+③振动盘落勺+④双头粉末灌装机(配真空上料+重量选别功能)+⑤三台抽真空充氮气封罐机+⑥激光打码机+⑦翻转机构+⑧罐外清洁机+⑨压盖机+⑩收瓶机
Machine Name	①Bottle Feeder+②UV Sterilization Machine+③Vibrating Plate Spoon Feeder+④Double Heads Powder Filling Machine(With Vacuum Feeding And Weight Selection Function)+⑤Three Sets Vacuum Can Sealing Machine With Nitrogen Flush+⑥Laser Coding Machine+⑦Flipping Mechanism+⑧External Can Cleaning Machine+⑨Plastic Lids Pressing Machine+⑩Collecting Table



特点 / Characteristic

1	直线式双机头充填,主充填和补充填,保证高精度灌装;	Linear double head filling,main filling and supplementary filling,ensure high precision Filling;
2	伺服及气动系统控制托罐及水平走罐,定位准、速度快;	Servo and pneumatic system control can support and horizontal moving,accurate positioning and fast speed;
3	伺服马达及伺服驱动控制螺杆,性能稳定、精度高;	Servo motor and servo drive control screw have stable performance and high precision;
4	全不锈钢结构;水平开启式料箱(里外抛光),清洗十分方便;	All stainless steel structure;Horizontal open material box(inside and outside polishing),cleaning is very convenient;
5	灌装后配重量剔除装置,自动剔除不合格产品;	After filling, a weight removal device is equipped to automatically remove unqualified products;
6	配有除尘装置,接负压管道,无粉尘污染环境;	Equipped with dust removal device,connected with negative pressure pipe,no dust pollution to the environment;
7	固定式螺杆安装结构,罐装时不产生金属污染。	Fixed screw installation structure,can not produce metal pollution;

样品 / Sample



技术参数 / Technical parameter

型号(Model)	LFPD-50-30	功率(Power)	4.5KW
灌装重量(Filling weight)	100-1000g(1000-5000g customize)	工作电源(Voltage)	220V,50Hz
罐子直径(Bottle diameter)	φ30-φ153mm(定制/customize)	工作气压(Air pressure)	0.6-0.8MPa
罐子高度(Bottle height)	60-260mm	料仓容积(Hopper volume)	50L ,30L
产量(Speed)	15-30罐bottle/min	重量(Weight)	500kg
灌装精度(Accuracy)	500g≤±2g		

Automatic Powder Filling Production Line

粉末全自动灌装生产线



二维尺寸图 / Drawing

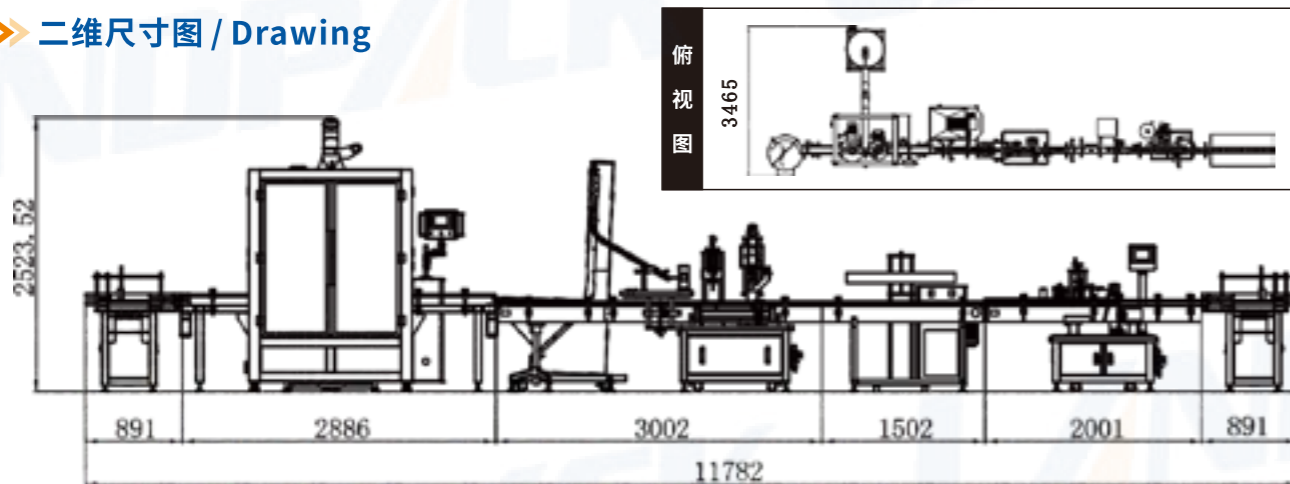

配套机组	①理瓶机+②螺杆上料机+③双头灌装机+④瓶盖提升机+⑤伺服旋盖机+⑥铝箔封口机+⑦贴标机+⑧收集平台
Machine Name	① Bottle Feeder+② Powder Feeder+③ Double Heads Powder Filling Machine+④ Caps Feeder+⑤ Servo Capping Machine+⑥ Foil Induction Sealing Machine+⑦ Labeling Machine+⑧ Collecting Table

样品 / Sample



特点 / Characteristic

1	本生产线配套机器除注明材料外均为不锈钢；	The machines of this production line are all stainless steel except the materials indicated;
2	所有机器结构均是按照食品卫生标准选用设计的；	All the machine structures are selected and designed according to the food hygiene standards;
3	具有吸扬尘装置，不会污染环境及设备；	With dust absorption device,it wil not pollute the environment and equipment;
4	双螺杆头充填，保证高精度灌装；	Double screw head filling ensures high-precision filling;
5	包装线主要适用于各种粉剂物料的包装，如五谷杂粮粉，营养粉，奶粉，鸡精粉等；	The packing line is mainly suitable for the packaging of various powder materials,such as grain powder,nutrition powder,milk powder,chicken powder,etc;

Automatic Single Head Powder Filling Line

单头粉剂灌装线



二维尺寸图 / Drawing

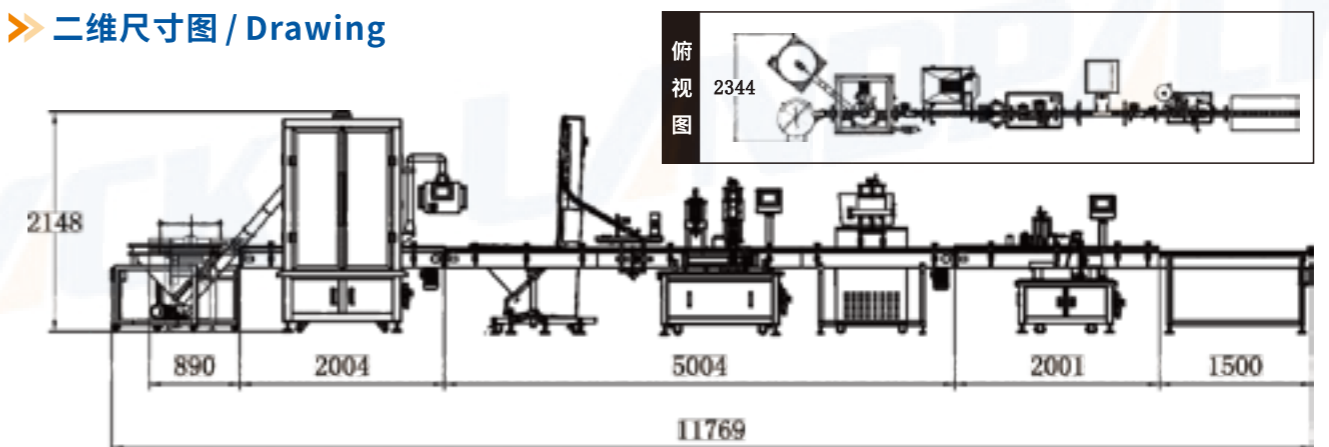

配套机组	①螺杆上料机+②粉末灌装机+③自动上盖机+④旋盖机+⑤铝箔封口机+⑥圆瓶贴标机+⑦收集平台
Machine Name	① Powder Feeder+② Powder Filling Machine+③ Caps Feeder+④ Capping Machine+⑤ Aluminum Foil Induction Sealing Machine+⑥ Round Bottle Labeling Machine+⑦ Bottle Collecting Table

特点 / Characteristic

1	整机全不锈钢作，特别适用GMP认证，食品卫生认证，要求抗腐蚀化工产品等的包装；	The whole machine is made of stainless steel,especially suitable for GMP certification food hygiene certification,anti-corrosion chemical products packaging;
2	触摸屏人机界面，工作稳定、抗干扰、称重精度高、操作便捷，直观。包装重量随时可级可调。工作状态随时任意变换，操作便捷；	Touch screen human-machine interface,stable work,anti-interference,high weighing accuracy,convenient operation,intuitive.The packing weight can be adjusted stepless at any time.The working state can be changed at any time,and the operation is convenient;
3	充填采用伺服电机，具有定位准确、精度高、速度快、扭矩大、寿命长、转速可设定、稳定性好等优点；	The filling adopts servo motor,which has the advantages of accurate positioning, high precision,high speed,large torque,long service life,adjustable speed and good stability;
4	搅拌采用台产免保养减速机：噪声低、寿命长；	The mixer adopts a maintenance free motor with low noise and long service life;
5	设计成称得反馈比重跟踪式，克服了因物料比重变化而致使重量发生变化的缺点；	It is designed as a feedback proportion tracking type,which overcomes the shortcomings of weight change caused by material proportion change;
6	全密封空气阻隔玻璃不锈钢侧开式复合料箱，物料动静一目了然，粉尘不外泄，充填出口吸吸尘装置，保护车间环境；	Fully sealed air blocking glass stainless steel side open compound material box, material movement and static at a glance,dust does not leak,filling outlet suction device,protect the workshop environment;
7	更换螺旋附件，能够适应超细粉到大颗粒等多种物料；	Replace screw accesores,can adapt to superfine powder to large particles and other materials;

Automatic High Speed Rotary Continuous Powder Filling Line 全自动转盘连续式高速粉末灌装线



二维尺寸图 / Drawing

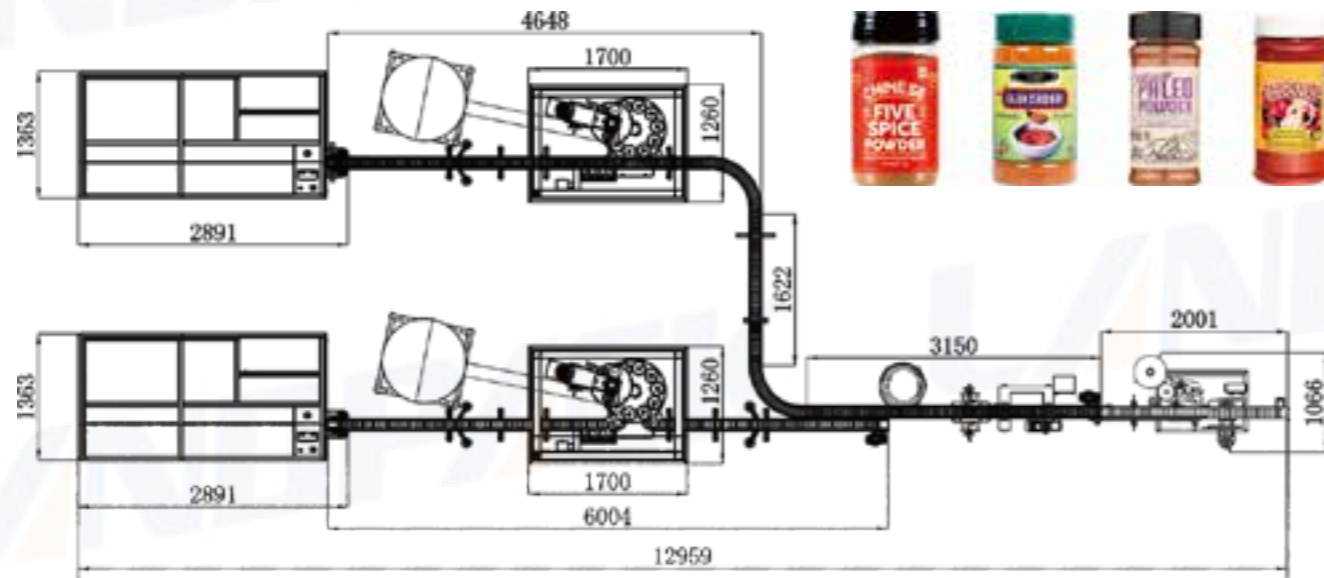

样品 / Sample



配套机组	①中速理瓶机+②螺杆粉末上料机+③高速旋转式粉末灌装机+④振动盘上盖+⑤压盖机+⑥圆瓶贴标机+⑦收集平台
Machine Name	① Bottle Feeder+② Screw Powder Feeder+③ Rotary Continuous High Speed Powder Filling Machine +④ Vibration Caps Feeder+⑤ Caps Pressing Machine+⑥ Labeling Machine+⑦ Bottle Collecting Table

特点 / Characteristic

1	全自动中速理瓶机, 速度快;	Automatic bottle sorting and feeding machin, fast speed;
2	转盘连续式粉末灌装机, 节省瓶子等待时间, 提高速度, 一台灌装机速度可达到40-60瓶一分钟	Rotary continuous powder filling machine saves bottle waiting time and mproves speed. One filling machine can reach a speed of 40-60 bottles per minute;
3	伺服电机控制螺杆计量, 精度高	Servo motor control filling, high accuracy;
4	不同重量, 瓶子尺寸可以调节	Different weights and bottle sizes can be adjusted;
5	可配备旋盖机贴标机打码机等连线使用	Can be equipped with a capping machine, labeling machine, coding machine, etc. for use on the entire production line.

Automatic Double Heads Rotary Powder Filling Line 全自动双头转盘式粉末灌装线



二维尺寸图 / Drawing

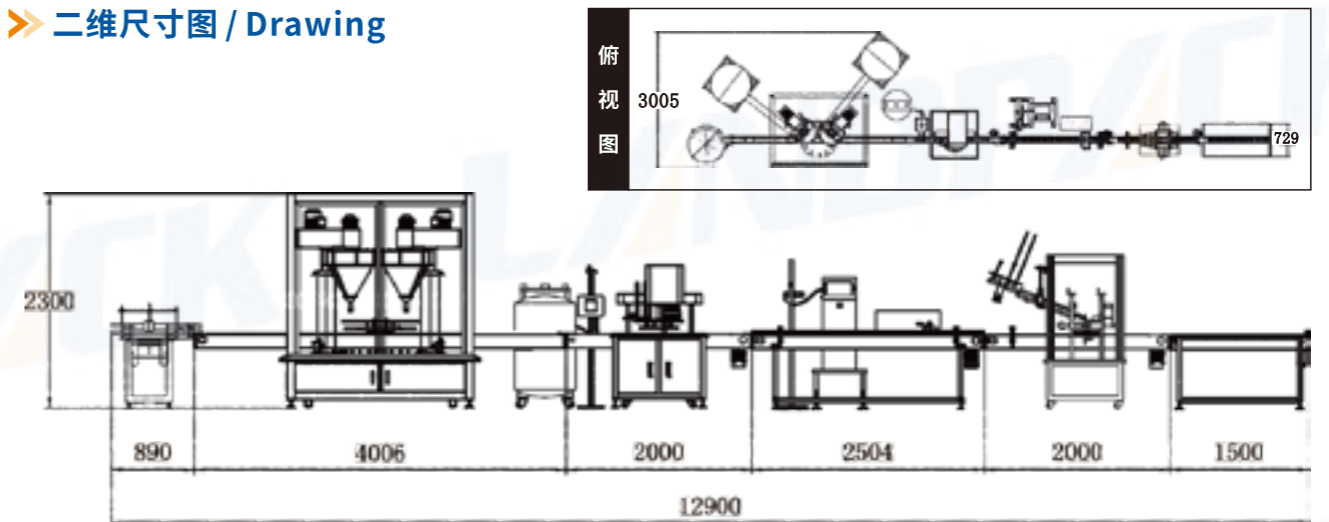

配套机组	①理瓶机+②螺杆粉末上料机+③转盘式双头粉末灌装机+④封罐机+⑤激光打码机+⑥翻转机构+⑦扣盖机+⑧收瓶机
Machine Name	① Bottle Feeder+② Screw Powder Feeder+③ Rotary Double Heads Powder Filling Machine+④ Can Sealer +⑤ Laser Printer+⑥ Flip Device+⑦ Lids Pressing Machine+⑧ Collecting Table

样品 / Sample



特点 / Characteristic

1	转盘式双头灌装机, 提高速度;	Rotary double head filling machine, improving speed;
2	充填螺旋采用伺服电机传动, 具有定位准确、精度高、速度快、扭矩大、寿命长、转速可设定、稳定性好等优点;	The filling spiral adopts servo motor transmission, which has the advantages of accurate positioning, high accuracy, fast speed, large torque, long service life, adjustable speed, and good stability;
3	更换螺旋附件快捷, 能够适应超细粉到小颗粒等多种物料的罐装需要。	Quick replacement of spiral attachments, able to adapt to the canning needs of various materials ranging from ultra-fine powder to small particles.

Automatic Three Heads Powder Filling Line 三头粉剂灌装线



>> 二维尺寸图 / Drawing

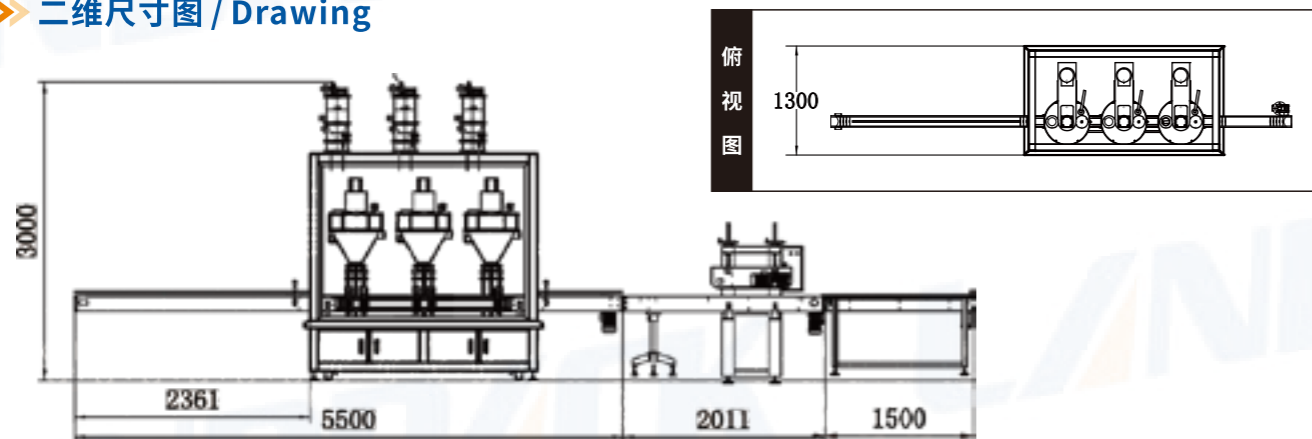

配套机组	①粉末储存罐+②真空上料机+③三头粉末灌装机+④链板压盖机+⑤收集平台
Machine Name	①Powder Storage Tank+②Vacuum Feeder+③Automatic Three Heads Powder Filling Machine+④Pressing Machine+⑤Collecting Table

>> 样品 / Sample



>> 特点 / Characteristic

1	配真空上料机, 自动输送粉末到料仓, 节省人工, 减少扬尘	Equipped with a vacuum feeder, it automatically delivers powder to the filling machine hopper, saving labor and reducing dust;
2	伺服电机控制螺杆计量, 稳定精度高	Servo motor controls screw measurement, with stability and high accuracy;
3	三头同时灌装, 提高速度	Three heads filling at same time to increase speed
4	包装线主要适用于各种粉剂物料的包装, 如五谷杂粮粉, 营养粉, 奶粉, 鸡精粉等;	The packing line is mainly suitable for the packaging of various powder materials, such as grain powder, nutrition powder, milk powder, chicken powder, etc;

Automatic Double Heads Powder Filling Machine 粉末自动灌装机



>> 适用物料 / Application



>> 二维尺寸图 / Drawing

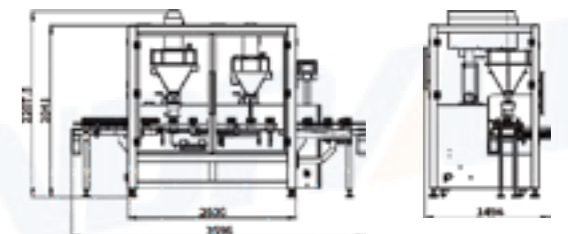

>> 样品 / Sample



>> 特点 / Characteristic

1	直线式双机头充填, 主充填和补充, 保证高精度灌装;	Linear double head filling, main filling and supplementary filling, ensure high precision filling;
2	伺服及气动系统控制托罐及水平走罐, 定位准、速度快;	Servo and pneumatic system control can support and horizontal moving, accurate positioning and fast speed;
3	伺服马达及伺服驱动控制螺杆, 性能稳定、精度高;	Servo motor and servo drive control screw have stable performance and high precision;
4	全不锈钢结构; 水平开启式料箱(里外抛光), 清洗十分方便;	All stainless steel structure; Horizontal open material box (inside and outside polishing), cleaning is very convenient;
5	充填头配有手轮调整高度, 轻松实现各种罐型灌装;	The filling head is equipped with a hand wheel to adjust the height, so it can easily fill all kinds of cans;
6	配有除尘装置, 接负压管道, 无粉尘污染环境;	Equipped with dust removal device, connected with negative pressure pipe, no dust pollution to the environment;
7	固定式螺杆安装结构, 灌装时不产生金属污染。	Fixed screw installation structure, can not produce metal pollution;

>> 技术参数 / Technical parameter

型号(Model)	LFPD-50-30	功率(Power)	4.5KW
灌装重量(Filling weight)	100-2000g(1000-5000g customize)	工作电源(Voltage)	220V, 50Hz
罐子直径(Bottle diameter)	φ30-φ153mm(定制/customize)	工作气压(Air pressure)	0.6-0.8MPa
罐子高度(Bottle height)	60-260mm	料仓容积(Hopper volume)	50L, 30L
产量(Speed)	10-25罐/bottle/min	重量(Weight)	700kg
灌装精度(Accuracy)	500g ≤ ±2g		