

让世界的包装因揽德更美好

Make the world's packaging be better because LANDPACK

**LANDPACK**

揽德包装机械



中文官网



English Web

# DOYPACK FILLING MACHINE CATALOG

给袋机画册



佛山市揽德包装机械有限公司

FOSHAN LAND PACKAGING MACHINERY CO.,LTD

地址：广东省佛山市南海区狮山镇下柏第一工业区吉祥路9号智展科技产业园

Add: Zhisheng Technology Industrial Park, No. 8 Jixiang Road, Xiabai First Industrial Zone,  
Shishan Town, Nanhai District, Foshan, Guangdong, China

Tel: 0757-81807872 Fax: 0757-81807758

网址: www.landpack.cn Web: www.landpack.com

E-mail: yang@landpacking.com

佛山市揽德包装机械有限公司

FOSHAN LAND PACKAGING MACHINERY CO.,LTD



# About LandPack

## 关于揽德

Foshan Land Packaging Machinery Co., Ltd. is located in Foshan, Guangdong Province, within a one-hour drive from Guangzhou Airport and just 20 minutes from Foshan High-Speed Railway Station. Established in 2017, the company is a high-tech enterprise integrating R&D, manufacturing, sales, and service. With a modern factory covering 30,000 square meters, Landpack is equipped with a team of senior engineers, installation and commissioning technicians, and marketing & after-sales service professionals. With over 130 employees, we provide customers with professional products and reliable service support.

Since its establishment, Landpack has been dedicated to the R&D and manufacturing of vertical form fill seal machines, filling machines, premade pouch packaging machines, multi lane packaging machines, flow pack machines, and feeding and packaging lines. Our products are widely applied in industries such as snacks food and health supplements, pet food, daily chemical products, fresh produce, sauces, and powders, offering customized and complete packaging solutions for enterprises.

Our products have obtained lots of national patent certificates, ISO9001 Quality Management System certification, as well as CE, TUV, SGS, and FDA approvals. They are exported to more than 100 countries and regions worldwide, receiving wide recognition and praise from customers.

At Landpack, we are committed to continuously refining and optimizing our products to deliver intelligent packaging equipment that is efficient, stable, safe, and beautiful packaging—striving to go beyond expectations and make the world a better place with Landpack Packaging.

佛山市揽德包装机械有限公司坐落于广东省佛山市，位于广州机场一小时，佛山动车站二十分钟交通圈。公司成立于2017年，是一家集研发、制造、销售及服务于一体的高新技术企业，配备三万平米现代化厂房，拥有骨干工程师，安装调试技术团队和营销与售后技术服务团队，员工规模达130人，为客户提供专业的产品和服务保障。

我司自成立以来，专注于研发和制造立式包装机，灌装机，给袋式包装机，多列机和枕式机、理料线包装设备，产品广泛用于休闲零食食品、食品保健品，宠物食品，日用化工用品，果蔬生鲜，酱料和粉剂等行业，致力为企业客户定制和提供整体包装解决方案。

产品已获多个国家技术专利证书，并通过ISO9001质量管理体系认证，获欧盟CE，TUV，SGS，FDA认证。产品远销海外一百多个国家和地区，受到企业客户广泛好评和认可。

揽德人将持续深耕和优化产品，为客户提供高效，稳定，安全，包装美观的智能包装设备，并力求超越，让世界因揽德包装而更美好。



## Development History of LandPack

### 揽德发展历程

#### 2025-NOW

##### Development 发展

After thorough preparation, the company officially relocated from its 10,000m<sup>2</sup> old factory to a new 30,000m<sup>2</sup> modern plant. The expanded space accommodates more production lines and R&D areas, not only meeting the growing demand for capacity but also providing employees with an enhanced working environment. This relocation marks more than a physical upgrade—it represents a new milestone for high-quality development, empowering LANDPACK to serve customers with stronger capabilities and move forward with greater momentum.

历经筹备，公司正式从1万方旧厂房，乔迁至3万方新址！新厂房空间扩容，可承载更多生产线与研发区域，既解产能增长之需，也为员工提供更优环境。这不仅是物理空间的升级，更是公司迈向高质量发展的新起点，未来将以更强实力服务客户、聚力前行。

#### 2019-2024

##### Expansion 壮大

The Landpack's factory has expanded to 10,000 square meters, establishing dedicated departments for premade pouch machines, multilane packaging machines, and filling machines, along with a supporting machining center. The team has grown with the addition of senior engineers, experienced installation and commissioning technicians, as well as marketing and after-sales professionals, bringing the workforce to 140 employees. Our sales team has actively promoted the LANDPACK brand by participating in major exhibitions in Germany, Thailand, and across China, including Shanghai and Qingdao. Drawing on deep expertise in packaging solutions for snacks, pet food, daily chemical products, health supplements, and pharmaceuticals, the company delivers over 180 customized full-line packaging solutions annually, achieving a turnover of 80 million RMB.

厂房规模扩大至一万平方米，建立给袋机产品部门，多列机产品部门和灌装机产品部门，并建立配套机加工中心，新增多名骨干工程，资深安装调试技术员，营销和售后技术人员，员工规模达140人，继销售团队参加海外德国展、泰国展，及国内上海、青岛等多个展会进行品牌营销。结合公司团队深耕积累休闲零食食品，宠物食品，日用化工，保健品药品行业包装技术方案经验。一年为客户定制提供180多个整线包装方案，公司营业额达8000万。

#### 2017-2018

##### Established 成立

LANDPACK brand was established, independently developed and manufactured vertical machines and pillow machines, obtained ISO9001 quality management system certification, EU CE, TUV, SGS, FDA certification, and its products were exported to more than 60 countries and regions, and has been widely praised and recognized by corporate customers.

LANDPACK揽德品牌建立，自主研发生产制造立式机和枕式机，获ISO9001质量管理体系认证，欧盟CE，TUV，SGS，FDA认证，产品远销六十多个国家和地区，受到企业客户广泛好评和认可。





## Technical strength 技术实力



CE 认证



CE 认证



CE 认证



Rohs证书



TUV 认证

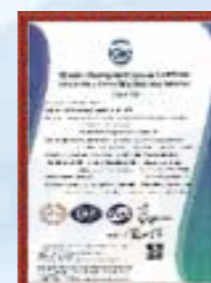

ISO 认证



SGS 认证



专利证书



专利证书



专利证书



专利证书



专利证书



专利证书



专利证书



专利证书

# Sales Marketing And Technical Services

## 营销和技术服务



**200+**  
Industry packaging solution cases  
every year

**100%**  
After-sales technical service support



# LandPack Exhibitions

## 揽德展会





# 目/录

# CONTENTS >>>>

<b>水平给袋包装机</b>	<b>Doypack Filling Machine</b>	P01
自动粉末预制袋灌装包装方案	Automatic Powder Doypack Filling Machine Packaging Solution	P03
自动颗粒预制袋包装方案	Automatic Granular Doypack Filling Machine Packaging Solutions	P05
自动液体预制袋包装方案	Automatic Liquids Doypack Filling Machine Packaging Solution	P06
双给袋/四给袋水平包装机	High speed horizontal doypack filling machine	P07
自动液体预制袋包装方案抽真空预制袋包装机	Automatic Vacuum Doypack Filling Machine Packaging Solution	P09
高速液体双上袋给袋机	High Capacity Liquid Pouch Bags Filling Machine	P10
<b>四工位预制袋包装机</b>	<b>Compact Doypack Filling Machine</b>	P11
<b>单工位给袋包装机</b>	<b>Compact Doypack Filling Machine</b>	P13
自动颗粒预制袋包装方案	Automatic Granular Doypack Filling Machine Solution	P15
粉末预制袋包装方案	Automatic Powder Doypack Filling Machine Solution	P19
液体预制袋包装方案	Automatic Liquids Doypack Filling Machine Solution	P20
大重量预制袋包装方案	2-10kgs Automatic Doypack Filling Machine Solution	P21
<b>LD 系列旋转给袋包装机</b>	<b>LD Series Rotary Packaging Machine</b>	P23
颗粒组合称量旋转给袋包装机	Granule Rotary Packing Machine	P25
粉末计量旋转给袋包装机	Powder Rotary Packing Machine	P26
液体计量旋转给袋包装机	Liquid Rotary Packing Machine	P27
给袋机真空包装机	Rotary Vacuum Doypack Filling Machine	P28
<b>配套设备</b>	<b>Other Supporting Equipments</b>	P29

# Doypack Filling Machine

## 水平给袋包装机

LDSP-160/210/260



### (一) 常规机械组成

- 1.触摸屏
- 2.打印机
- 3.变频器
- 4.温控仪
- 5.真空开袋装置
- 6.送袋装置
- 7.光电检测元件
- 8.PLC控制系统
- 9.输出装置

### (二) 主要性能和结构特点

- 放袋槽放袋方便简单, 配备自动压袋装置;
- 配置进口压力感应装置, 达到不下料不封的效果, 节约包装袋;
- 采用彩色触摸式显示屏, 简单操作, 多功能设计;
- 机器采用不锈钢304L外观, 碳钢机架部分与部分配件做耐酸、耐盐防腐处置层加工。
- 选材要求: 大部分配件以模具化生产成型, 主要材料选用304不锈钢与氧化铝。
- 可选配各种打码、喷码、排气、冲孔系统;

### Option

- 1.Touch screen
2. Code printer
3. Inverter
4. Temperature controller
5. Vacuum bag opening device
- 6.Bag feeder
- 7.photoelectric detection sensor
- 8.PLC control system
- 9.Bag outputer

### Feature

- The bag-feeding slot is convenient and simple to place bags, and is equipped with an automatic bag-pressing device.
- It is equipped with an imported pressure sensing device to achieve no blanking or sealing.
- Use color touch screen, simple operation, multi-functional design.
- The machine adopts stainless 304L appearance, and the carbon steel frame part and some accessories are processed with acid and salt resistant anti-corrosion treatment layer.
- Material selection requirements: Most of the accessories are formed by mold production, and the main materials are 304 stainless steel and alumina.
- Various coding, coding, exhaust, and punching systems are optional.

### (三) 适用范围

- 块料: 豆腐、蛋糕、鱼、鸡蛋、糖果、红枣、谷物、巧克力、饼干、花生等。
- 颗粒类型: 结晶味精、颗粒药物、胶囊、种子、化学品、糖、鸡精、甜瓜、坚果、农药、肥料等。
- 粉型: 奶粉、葡萄糖、味精、调味品、洗衣粉、化学原料、细白糖、农药、肥料等。
- 糊类型: 洗涤剂、米酒、酱油、米醋、果汁、饮料、番茄酱、花生酱、果酱、辣椒酱、豆酱、洗发水、发膏。
- 泡菜、腌菜、泡菜、泡菜、萝卜等。

### Applications

- Block material: bean curd cake, fish, eggs, candy, red jujube, cereal, chocolate, biscuit, peanut, etc.
- Granular type: crystal monosodium glutamate, granular drug, capsule, seeds, chemicals, sugar, chicken essence, melon seeds, nut, pesticide, fertilizer, etc.
- Powder type: milk powder, glucose, monosodium glutamate, seasoning, washing powder, chemical materials, fine white sugar, pesticide, fertilizer, etc.
- Liquid/paste type: detergent, rice wine, soy sauce, rice vinegar, fruit juice, beverage, tomato sauce, peanut butter, jam, chili sauce, bean paste, Shampoo, hair cream.
- Class of pickles, pickled cabbage, kimchi, pickled cabbage, radish, etc.

### (四) 技术参数 / Specification

机器型号 (Type)	水平给袋包装机 (Doypack Filling Machine)		
	LDSP-140	LDSP-160/LDSP-210	LDSP-260
包装袋型 (Bag Type)	三边封, 四边封袋, 自立袋, 手提袋、壶口袋、拉链袋、复合袋等 3-side, 4 side sealing bag, stand-up bag, handbag, spout bags, zipper bag, compound bag, etc.		
包装尺寸 (Bag Size)	70-140mm*110-230mm(W*L)	70-160mm*110-230mm(W*L) 100-210mm/110-320mm(W*L)	110-260mm/160-380mm (W*L)
填充范围 (Filling Range)	20g-500g	20g-1000g	20g-1000g
包装速度 (Packing Speed)	20-45袋/分钟(速度由产品填充量) 20-45bags/min(speed is determined by the product filling quantity)	20-50袋/分钟(速度由产品填充量) 20-50bags/min(speed is determined by the product filling quantity)	20-40袋/分钟(速度由产品填充量) 20-40bags/min(speed is determined by the product filling quantity)
机器重量 (machine Weight)	800KG	900KG	900KG
总功率 (Total Power)	5.5KW	5.5KW	5.5KW
外形尺寸 (Dimensions)L*W*H	1750mm * 1285mm * 1360mm	2140mm * 1366mm * 1360mm	2140mm * 1366mm * 1360mm

### 工作流程 Work Process

- ①取袋 (Giving bag)
- ②拿袋 (打码) Pick up the bag(coding)
- ③上下开袋 Open the bag up and down
- ④下料 Filling
- ⑤热封 Heating sealing
- ⑥输出产品 Output of product

### (五) 包装袋型 / Packing Examples



# Automatic Powder Doypack Filling Machine Packaging Solution

## 自动粉末预制袋灌装包装方案

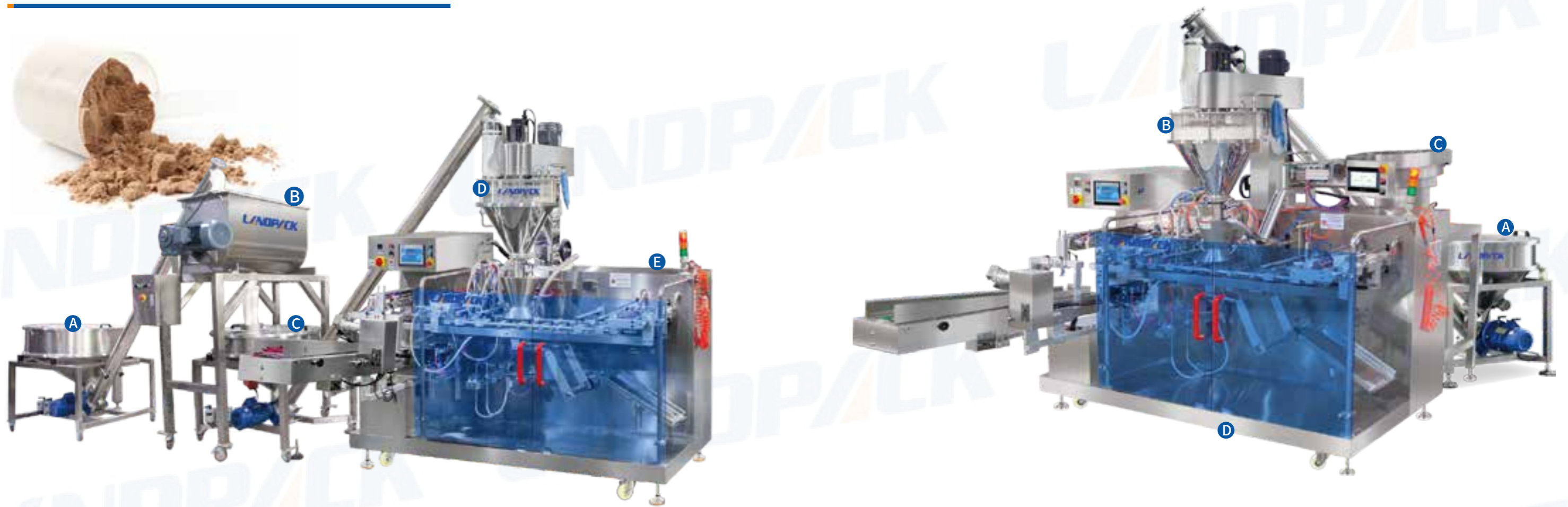

序列号(Serial Number)	描述(Describe)	功能(Function)
A	螺杆上料机 Auger screws feeding conveyor	送料到粉末混合搅拌罐 Feeding the powder to the mixer tank
B	粉末搅拌罐 Mixer tank	混合搅拌不同粉体物料 Mixing the powde
C	螺杆上料机 Auger screws feeding conveyo	自动上料到包装机 Auto feeding the ready powder to the packing machine
D	螺杆粉剂定量下料系统 Auger screws dosing filler	定量下料到预制袋 Filling the powder to the bag
E	预制袋包装机 Doypack filling machine	自动送袋, 自动开袋, 灌装, 封口和输出 Auto feeding the ready bags, auto open the bags, auto filling, auto heat sealing and output.

序列号(Serial Number)	描述(Describe)	功能(Function)
A	螺杆上料机 Auger screws feeding conveyor	自动上料到包装机 Auto feeding the powder to the packing machine
B	螺杆粉剂定量下料系统 Auger screws dosing filling device	定量下料到预制袋 Auto filling the powder to the bags
C	投勺机 Spoon feeder	自动投勺到袋子 Auto filling the spoon to the bag
D	预制袋包装机 Doypack filling machine	自动送袋, 自动开袋, 灌装, 封口和输出 Auto feeding the ready bags, Auto open the bags, Auto filling, Auto heat sealing and output.

### >> 包装样袋 / Sample



### >> 包装样袋 / Sample



## Automatic Granular Doypack Filling Machine Packaging Solutions 自动颗粒预制袋包装方案

## Automatic Liquids Doypack Filling Machine Packaging Solution 自动液体预制袋包装方案



序列号(Serial Number)	描述(Describe)	功能(Function)
A	皮带上料机 Belt feeding conveyor	自动上料到包装机 Auto feeding the product materials to the packing machine
B	多头称重下料系统 Multihead electric weigher	自动称重和下料到袋子 Auto weighing and filling the product materials to the bags
C	预制袋包装机 Doypack filling machine	自动上袋, 自动开袋, 灌装, 封口和输出 Auto feeding the ready bags, Auto open the bags, Auto filling, Auto heat sealing and output.
D	金属检测机 Metal detector	自动检测和剔除含铁或不锈钢异物的包装 Automatically detect and reject packages containing iron or stainless steel foreign matter
E	重量检测机 Weight checker	自动检测和剔除超重或超轻的包装 Automatically detect and reject packages that are overweight or light

### >> 包装样袋 / Sample

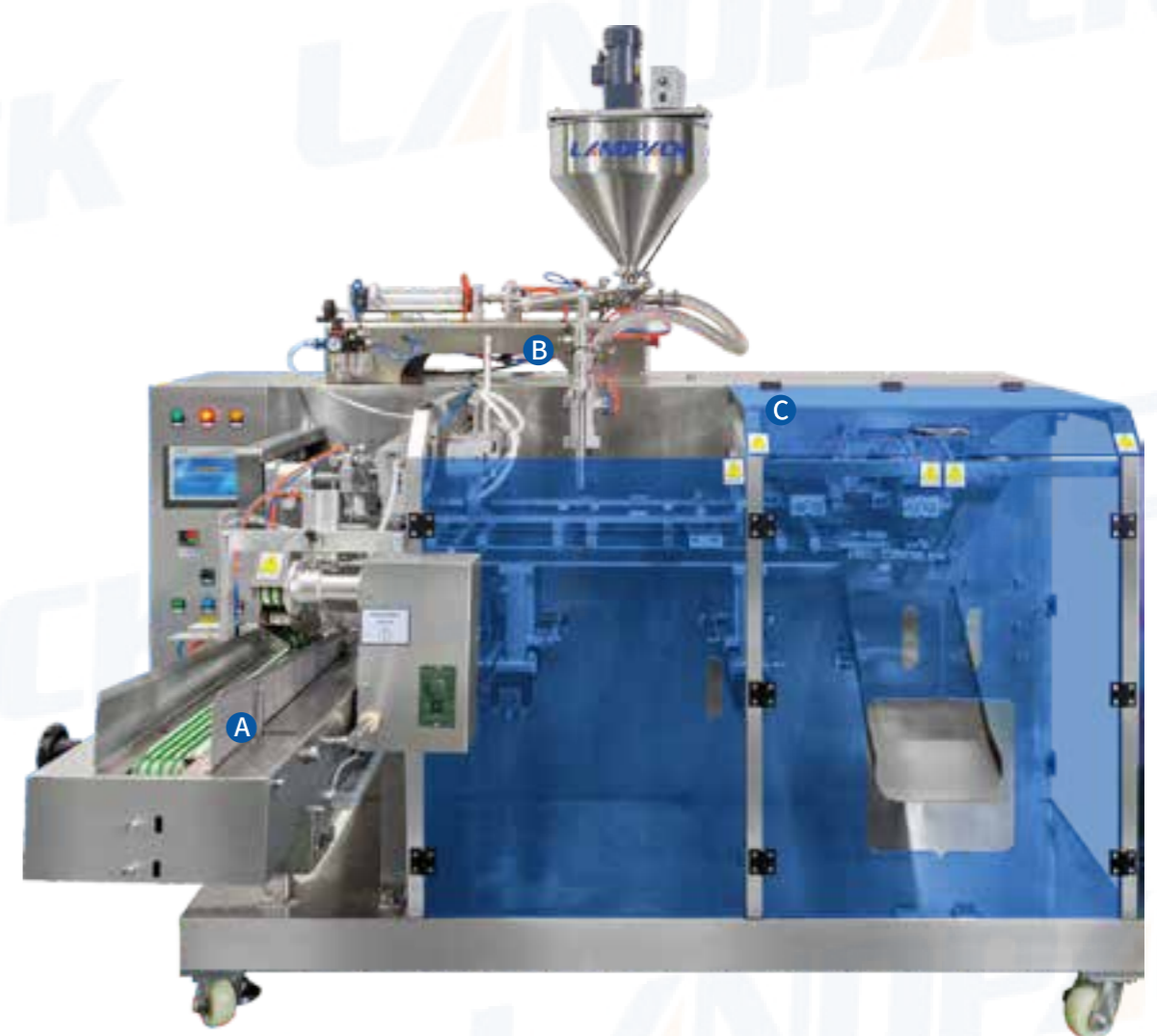

序列号(Serial Number)	描述(Describe)	功能(Function)
A	送袋机构 Bag feeder	自动送预制袋到包装机 Auto feeding the ready pouches to the machine
B	计量灌装液体泵 Volumetric pump filling system	自动计量和灌装液体到袋子 Auto filling the liquid products to the bags
C	预制袋包装机 Doypack filling machine	自动送袋, 自动开袋, 灌装, 封口和输出 Auto feeding the ready bags, Auto open the bags, Auto filling, Auto heat sealing and output.

### >> 包装样袋 / Sample



# High Speed Horizontal Doypack Filling Machine

## 双给袋/四给袋水平包装机

LDSP-140S/LDSP-85F



### (一) 常规机械组成

- 1. 打码机
- 2. PLC控制系统
- 3. 开袋装置
- 4. 振动装置
- 5. 气缸
- 6. 送袋装置
- 7. 光电检测元件
- 8. PLC控制系统
- 9. 输出装置

### (二) 主要性能和结构特点

- 放袋槽放袋方便简单, 配备自动压袋装置;
- 配置进口压力感应装置, 达到不下料不封的效果, 节约包装袋;
- 采用彩色触摸式显示屏, 简单操作, 多功能设计;
- 机器采用不锈钢304L外观, 碳钢机架部分与部分配件做耐酸、耐盐防腐处置层加工。
- 选材要求: 大部分配件以模具化生产成型, 主要材料选用304不锈钢与氧化铝。
- 可选配各种打码、喷码、排气、冲孔系统;

### Option

- 1. Touch screen
- 2. Code printer
- 3. Inverter
- 4. Temperature controller
- 5. Vacuum bag opening device
- 6. Bag feeder
- 7. photoelectric detection sensor
- 8. PLC control system
- 9. Bag outputter

### Feature

- The bag-feeding slot is convenient and simple to place bags, and is equipped with an automatic bag-pressing device.
- It is equipped with an imported pressure sensing device to achieve no blanking or sealing.
- Use color touch screen, simple operation, multi-functional design.
- The machine adopts stainless 304L appearance, and the carbon steel frame part and some accessories are processed with acid and salt resistant anti-corrosion treatment layer.
- Material selection requirements: Most of the accessories are formed by mold production, and the main materials are 304 stainless steel and alumina.
- Various coding, coding, exhaust, and punching systems are optional.

### (三) 适用范围

- 块料: 豆腐、蛋糕、鱼、鸡蛋、糖果、红枣、谷物、巧克力、饼干、花生等。
- 颗粒类型: 结晶味精、颗粒药物、胶囊、种子、化学品、糖、鸡精、甜瓜、坚果、农药、肥料等。
- 粉型: 奶粉、葡萄糖、味精、调味品、洗衣粉、化学原料、细白糖、农药、肥料等。
- 糊类型: 洗涤剂、米酒、酱油、米醋、果汁、饮料、番茄酱、花生酱、果酱、辣椒酱、豆酱、洗发水、发膏。
- 泡菜、腌菜、泡菜、泡菜、萝卜等。

### Applications

- Block material: bean curd cake, fish, eggs, candy, red jujube, cereal, chocolate, biscuit, peanut, etc.
- Granular type: crystal monosodium glutamate, granular drug, capsule, seeds, chemicals, sugar, chicken essence, melon seeds, nut, pesticide, fertilizer, etc.
- Powder type: milk powder, glucose, monosodium glutamate, seasoning, washing powder, chemical materials, fine white sugar, pesticide, fertilizer, etc.
- Liquid/paste type: detergent, rice wine, soy sauce, rice vinegar, fruit juice, beverage, tomato sauce, peanut butter, jam, chili sauce, bean paste, Shampoo, hair cream.
- Class of pickles, pickled cabbage, kimchi, pickled cabbage, radish, etc.

### (四) 技术参数 / Specification

机器型号 (Type)	LDSP-140S	LDSP-85F
包装袋型 (Bag Type)	三边封, 四边封袋, 自立袋, 手提袋、壶口袋、拉链袋、复合袋等 3-side, 4 side sealing bag, stand-up bag, handbag, spout bags, zipper bag, compound bag, etc.	
包装尺寸 (Bag Size)	90-140mm/100-250mm/(W*L)	60-90mm/100-300mm/(W*L)
填充范围 (Filling Range)	10-500ml	5-300ml
包装速度 (Packing Speed)	50-70bags/min (速度由产品填充量定) (speed is determined by the product filling quantity)	100-160bags/min (速度由产品填充量定) (speed is determined by the product filling quantity)
机器重量 (Machine weight)	900KG	1500KG
总功率 (Total Power)	6KW	7.5KW
工作流程 (Work Flow)	1.取袋 2.拿袋(打码) 3.上下开袋 4.下料 5.热封 6.输出产品 1. Giving bag 2. Pick up the bag(coding) 3. Open the bag up and down 4. Filling 5. Heating sealing 6. Output of product	
外形尺寸 (Dimensions)	3093mm x 1366mm x 1360mm(L*W*H)	3600mm x 1366mm x 1360mm(L*W*H)

### 工作流程 Work Process

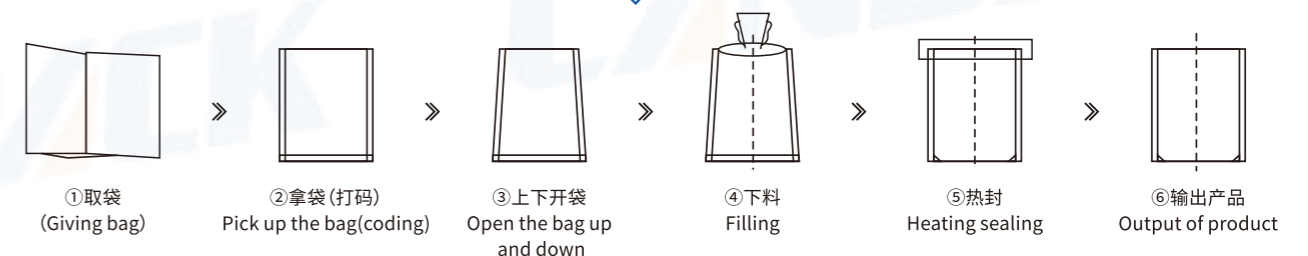

### (五) 包装样袋 / Sample



## Automatic Vacuum Doypack Filling Machine Packaging Solution 抽真空预制袋包装机

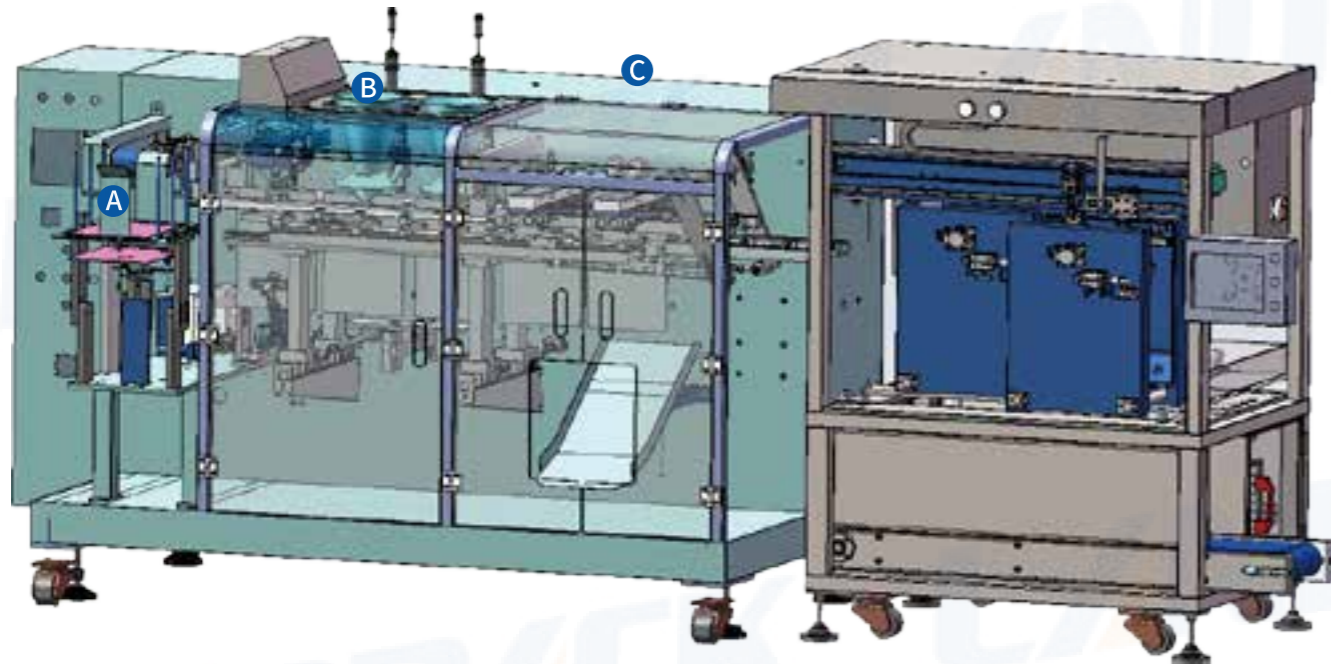

序列号 (Serial Number)	描述 (Describe)	功能 (Function)
A	送袋机构 Bag feeder	自动送预制袋到包装机 Auto feeding the ready pouches to the machine
B	定量下料系统 Filling dosing system	自动下料到袋子 Auto filling the product materials to the bags
C	预制袋抽真空包装机 Doypack filling and vacuum machine	自动送袋, 自动开袋, 下料灌装, 抽真空, 封口和输出 Auto feeding the ready bags, Auto open the bags, Auto filling, Auto vacuum the bags then sealing.

### » 包装样袋 / Sample



## High Capacity Liquid Pouch Bags Filling Machine 高速液体双上袋给袋机



序列号 (Serial Number)	描述 (Describe)	功能 (Function)
A	送袋机构 Bag feeder	自动送预制袋到包装机 Auto feeding the ready pouches to the machine
B	定量下料系统 Filling dosing system	自动下料到袋子 Auto filling the product materials to the bags
C	预制袋抽真空包装机 Doypack filling and vacuum machine	自动送袋, 自动开袋, 下料灌装, 抽真空, 封口和输出 Auto feeding the ready bags, Auto open the bags, Auto filling, Auto vacuum the bags then sealing.

### » 包装样袋 / Sample



# Compact Doypack Filling Machine

## 四工位预制袋包装机

LDG4-300/600



### (一) 常规机械组成

- 1.触摸屏
- 2.打印机
- 3.变频器
- 4.温控仪
- 5.真空开袋装置
- 6.送袋装置
- 7.光电检测元件
- 8.PLC控制系统
- 9.输出装置

### (二) 主要性能和结构特点

- 放袋槽放袋方便简单, 配备自动压袋装置;
- 配置进口压力感应装置, 达到不下料不封的效果, 节约包装袋;
- 采用彩色触摸式显示屏, 简单操作, 多功能设计;
- 机器采用不锈钢304L外观, 碳钢机架部分与部分配件做耐酸、耐盐防腐处置层加工。
- 选材要求: 大部分配件以模具化生产成型, 主要材料选用304不锈钢与氧化铝。
- 可选配各种打码、喷码、排气、冲孔系统;

### Option

- 1.Touch screen
2. Code printer
3. Inverter
4. Temperature controller
5. Vacuum bag opening device
- 6.Bag feeder
- 7.photoelectric detection sensor
- 8.PLC control system
- 9.Bag outputer

### Feature

- The bag-feeding slot is convenient and simple to place bags, and is equipped with an automatic bag-pressing device.
- It is equipped with an imported pressure sensing device to achieve no blanking or sealing .
- Use color touch screen, simple operation, multi-functional design.
- The machine adopts stainless 304L appearance, and the carbon steel frame part and some accessories are processed with acid and salt resistant anti-corrosion treatment layer.
- Material selection requirements: Most of the accessories are formed by mold production, and the main materials are 304 stainless steel and alumina.
- Various coding, coding, exhaust, and punching systems are optional.

### (三) 适用范围

- 块料: 豆腐、蛋糕、鱼、鸡蛋、糖果、红枣、谷物、巧克力、饼干、花生等。
- 颗粒类型: 结晶味精、颗粒药物、胶囊、种子、化学品、糖、鸡精、甜瓜、坚果、农药、肥料等。
- 粉型: 奶粉、葡萄糖、味精、调味品、洗衣粉、化学原料、细白糖、农药、肥料等。
- 糊类型: 洗涤剂、米酒、酱油、米醋、果汁、饮料、番茄酱、花生酱、果酱、辣椒酱、豆酱、洗发水、发膏。
- 泡菜、腌菜、泡菜、泡菜、萝卜等。

### Applications

- Block material: bean curd cake, fish, eggs, candy, red jujube, cereal, chocolate, biscuit, peanut, etc.
- Granular type: crystal monosodium glutamate, granular drug, capsule, seeds, chemicals, sugar, chicken essence, melon seeds, nut, pesticide, fertilizer, etc.
- Powder type: milk powder, glucose, monosodium glutamate, seasoning, washing powder, chemical materials, fine white sugar, pesticide, fertilizer, etc.
- Liquid/paste type: detergent, rice wine, soy sauce, rice vinegar, fruit juice, beverage, tomato sauce, peanut butter, jam, chili sauce, bean paste, Shampoo, hair cream.
- Class of pickles, pickled cabbage, kimchi, pickled cabbage, radish, etc.

### (四) 技术参数 / Specification

机器型号 (Type)	四工位预制袋包装机 (Compact Doypack Filling Machine)	
	LDG-300	LDG-600
包装材料 (Bag Material)	多层复合预制袋 Multi-layer Composite Premade Bag (e.g.: PET/PE)	
适用袋型 (Premade Bag Type)	三边封袋、自立袋 (3-sides sealing bag, stand-up bag)	
可升级袋型 (Upgraded Bag Type)	插角袋、拉链袋、盒形袋 (需额外购买功能装置) Gusset Bag, Zipper Bag, box bag (Need additional purchase of functional device)	
包装尺寸 (Bag Size)	80mm≤W≤300mm 100mm≤L≤300mm	250mm≤W≤500mm 380mm≤L≤600mm
速度 (Speed)	0~15bags/min	0~10bags/min
封口类型 (Sealing Type)	直纹, 齿距1mm (可选网纹) Straight grain, pitch is 1mm (Optional reticulate)	
封口宽度 (Sealing Width)	10mm (5--20mm) 可订做 can be customized	
电压 (Voltage)	220V, 单相, 50/60HZ, 1.2KW (220V, Single-phase, 50/60HZ, 1.2KW)	
气压 (Air Pressure)	0.65Mpa	
耗气量 (Air Consumption)	0.7m <sup>3</sup> /min标准机, 不含附加功能 (Standard machine, no additional function)	
机器尺寸 (Body Dimension)	1300*800*1230mm	2800*1200*1450mm
机器重量 (Machine Weight)	300kgs	450kgs

### 工作流程 Work Process

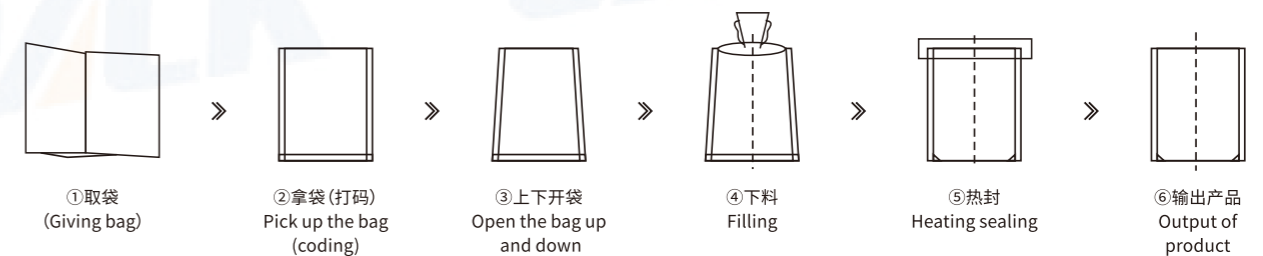

### (七) 包装样袋 / Sample



# Compact Doypack Filling Machine

## 单工位给袋包装机

LDB-300/430/600



### (一) 常规机械组成

1. 触摸屏
2. PLC控制系统
3. 气缸
4. 温度控制器
5. 存袋器
6. 夹袋器
7. 下料斗
8. 开袋器

### (二) 辅助功能装置(选配)

1. 拉链开
2. 保护夹子
3. 真空泵

### (三) 主要性能和机构特点

- 本机器专门为各类复合膜预制袋的包装应用研制;
- PLC和人机界面控制,方便参数设定和故障排除;
- 应用不同袋大小,调整简单,无需工具;
- 智能控温配置,封口美观、整齐;
- 省袋设计,无完全打开袋,无灌装和封口;
- 粉体、颗粒、液体配比兼容程序,即插即用,方便不同产品切换
- 门打开机器即停止运作。

### Option

- 1.The couch screen
2. PLC control system
3. Cylinder
- 4.Temperature controller
5. bag depositor
6. Bag gripper
7. Bag hopper
- 8.Pouch opening devices

### Auxiliary function device (optional):

- 1.zipper opener
- 2.protect the clip
3. vacuum pump

### Feature

- Machine is specially developed for all kinds of composite pre-made bags.
- PLC & HMI Control , Easy for parameter setting and troubleshooting.
- Different pouch size adaption, simple adjustment without tools.
- Intelligent temperature controlling configuration, ensure the artistic and neat sealing.
- Pouch saving design, no completely opened pouch, no filling and sealing.
- Compatible Programs of powder, granule or liquid dosing, easy for different products switching.
- Machine stoped when the door is opened.

### (四) 可选功能

- 小袋拉链开启功能;
- 风琴袋开启功能;
- 气冲功能,保持产品新鲜,避免产品破损;
- 空气/氮气充、放气功能;
- 真空功能,保持产品新鲜,减少包装空间;
- 抽袋机振动压实功能,使产品落到袋底,提高包装密度;
- 夹持密封,以避免粉末在灌装过程中出来;
- 设有除尘装置,使包装环境清洁,确保封口质量;
- 不同类型码印功能,热印色带打印机、喷墨打印机、热转印打印机等。

### Optional Features

- Pouch zipper opening function.
- Gusset pouch opening function.
- Gas flush function to keep the products fresh and avoid them broken.
- Air/Nitrogen Inflating, Air deflating function.
- Vacuum function to keep the products fresh and reduce the package space.
- Bag tapper vibrating compacting function help products drop to the bag bottom part and enhance packaging density.
- Grip seal to avoid powders coming out during filling.
- Dedusting device to enable clean packaging environment and ensure quality of sealing.
- Different types of code printing function, such as hot stamp ribbon printer, inkjet printer, thermal transfer printer and so on.

### (五) 技术参数 / Specification

机器型号 (Type)	单工位预制袋包装机 (Compact Doypack Filling Machine)		
	LDB-300	LDB-430	LDB-600
包装材料 (Bag Material)	多层复合预制袋 Multi-layer Composite Premade Bag (e.g.: PET/PE)		
适用袋型 (Premade bag type)	三边封袋、自立袋 (3-sides sealing bag, stand-up bag)		
可升级袋型 (Upgraded Bag Type)	插角袋、拉链袋、盒形袋 (需额外购买功能装置) Gusset Bag, Zipper Bag, box bag (Need additional purchase of functional device)		
包装尺寸 (Bag Size)	80mm≤W≤300mm 100mm≤L≤300mm	80mm≤W≤300mm 100mm≤L≤430mm	250mm≤W≤500mm 380mm≤L≤600mm
速度 (Speed)	0~15bags/min		0~10bags/min
封口类型 (Sealing Type)	直纹, 齿距1mm (可选网纹) Straight grain, pitch is 1mm (Optional reticulate)		
封口宽度 (Sealing Width)	10mm (5--20mm)可订做 can be customized		
电压 (Voltage)	220V, 单相,50/60HZ,1.2KW (220V, Single-phase,50/60HZ, 1.2KW)		
气压 (Air Pressure)	0.65Mpa		
耗气量 (Air Consumption)	0.7m <sup>3</sup> /min标准机, 不含附加功能 (Standard machine, no additional function)		
机器尺寸 (Body Dimension)	1770*600*1230mm		1677*1140*1450mm
机器重量 (Machine Weight)	300kgs	350kgs	450kgs

### (六) 适用范围 / Application

Landpack单工位预成型袋包装机适用于将粉状、颗粒状或液体灌装入预成型袋并封口, 具体应用说明如下表:

Landpack single station preformed pouch packing machine is applicable for dosing powder, granule or liquid into a premade pouch and sealing, the detail application description as following table:

通用 Application	应用说明 Application Description
适用袋型 Applicable Pouches	复合热封预制袋,如扁平袋,风琴袋,自立袋,或自立拉链袋等 Laminate heat sealable premade pouches like flat pouch , gusset pouch, normal stand up pouch, or stand up pouch with zipper etc
适用产品 Applicable Products	配置不同的灌装装置,可灌装液体、粉末、颗粒或其他不规则固体物料。 Configure with different dosing devices, capable to pack with liquid, powder, granule, or other irregular solidity materials.
适用包装材料 Applicable Packaging Material	OPP/PE、BOPP/OPP/PE、PET/AL等复合热密封包装材料 Laminate Heat sealable packing materials such as OPP/PE,BOPP/OPP/PE, PET/AL etc

### (七) 包装袋型 / Packing Examples



# Automatic Granular Doypack Filling Machine Solution

## 自动颗粒预制袋包装方案



序号(Serial Number)	描述(Describe)	功能(Function)
A	带振动盘电子称重灌装系统 Electrical weigher with vibration feeder	自动送料, 称重和灌装物料到袋子 Auto feeding, weighing and filling the product materials to the bags
B	预制袋包装机 Doypack filling machine	自动送袋, 自动开袋, 灌装, 封口和输出 Auto feeding the ready bags, auto open the bags, auto filling, auto heat sealing and output.
C	金属检测机 Metal detector	自动检测和剔除含铁或不锈钢异物的包装 Automatically detect and reject packages containing iron or stainless steel foreign matter

序号(Serial Number)	描述(Describe)	功能(Function)
A	Z型提升机 Z type feeding elevator	自动上料到包装机 Auto feeding the products to the machine
B	线性秤称重灌装 定量下料到预制袋 Linear electric weigher to weighing and filling the products to the bags	自动称重和灌装物料到袋子 Auto weighing and filling the product materials to the bags
C	预制袋包装机 Doypack filling machine	自动送袋, 自动开袋, 灌装, 封口和输出 Auto feeding the ready bags, Auto open the bags, Auto filling, Auto heat sealing and output.

### >> 包装样袋 / Sample



# Automatic Granular Doypack Filling Machine Solution

## 自动颗粒预制袋包装方案



序列号(Serial Number)	描述(Describe)	功能(Function)
A	Z型提升机 Z type feeding elevator	自动上料到包装机 Auto feeding the products to the machine
B	多头称重下料系统 Multihead electric weigher	自动称重和下料到袋子 Auto weighing and filling the product materials to the bags
C	预制袋包装机 Doypack filling machine	自动送袋, 自动开袋, 灌装, 封口和输出 Auto feeding the ready bags, Auto open the bags, Auto filling, Auto heat sealing and output.
D	储气罐 Gas Tank	用于储存氮气, 确保机器稳定运行 To storage the nitrogen gas for machine stable running
E	氮气发生器 Nitrogen generator	用于生成并向机器供应氮气 Generate and supply the nitrogen gas to the machine

序列号(Serial Number)	描述(Describe)	功能(Function)
A	Z型提升机 Z type feeding elevator	自动上料到包装机 Auto feeding the products to the machine
B	多头称重下料系统 Multihead electric weigher	自动称重和下料到袋子 Auto weighing and filling the product materials to the bags
C	预制袋包装机 Doypack filling machine	自动送袋, 自动开袋, 灌装, 封口和输出 Auto feeding the ready bags, Auto open the bags, Auto filling, Auto heat sealing and output.
D	金属检测机 Metal detector	自动检测和剔除含铁或不锈钢异物的包装 Automatically detect and reject packages containing iron or stainless steel foreign matter

### 包装样袋 / Sample



## Automatic Powder Doypack Filling Machine Solution 粉末预制袋包装方案

## Automatic Liquids Doypack Filling Machine Solution 液体预制袋包装方案



序列号 (Serial Number)	描述 (Describe)	功能 (Function)
A	螺杆上料机 Auger screws feeding conveyor	自动上料到包装机 Auto feeding the powder to the packing machine
B	螺杆粉剂定量下料系统 Auger screws dosing filling device	定量下料到预制袋 Auto filling the powder to the bags
C	预制袋包装机 Doypack filling machine	自动送袋, 自动开袋, 灌装, 封口和输出 Auto feeding the ready bags, Auto open the bags, Auto filling, Auto heat sealing and output.

序列号 (Serial Number)	描述 (Describe)	功能 (Function)
A	计量上料液体泵 Metering feeding pump	自动从储料送料并计量和灌装到包装机 Auto filling the liquids to the machine from the storage tank
B	预制袋包装机 Doypack filling machine	自动送袋, 自动开袋, 灌装, 封口和输出 Auto feeding the ready bags, Auto open the bags, Auto filling, Auto heat sealing and output.
C	成品输送机 Finished conveyor	成品输出 Finished product output

### >> 包装样袋 / Sample



### >> 包装样袋 / Sample



# 2-10kgs Automatic Doypack Filling Machine Solution

## 大重量预制袋包装方案



序列号(Serial Number)	描述(Describe)	功能(Function)
A	Z型提升机 Z type feeding elevator	自动上料到包装机 Auto feeding the powder to the packing machine
B	电子称重灌装系统 Electrical weigher filling system	自动称重和灌装物料到袋子 Auto weighing and filling the product materials to the bags
C	预制袋包装机 Doypack filling machine	自动送袋, 自动开袋, 灌装, 封口和输出 Auto feeding the ready bags, Auto open the bags, Auto filling, Auto heat sealing and output.

序列号(Serial Number)	描述(Describe)	功能(Function)
A	Z型提升机 Z type feeding elevator	自动上料到包装机 Auto feeding the powder to the packing machine
B	电子称重灌装系统 Electrical weigher filling system	自动称重和灌装物料到袋子 Auto weighing and filling the product materials to the bags
C	预制袋包装机 Doypack filling machine	自动送袋, 自动开袋, 灌装, 封口和输出 Auto feeding the ready bags, Auto open the bags, Auto filling, Auto heat sealing and output.

### >> 包装样袋 / Sample



### >> 包装样袋 / Sample



# LD Series Rotary Packaging Machine

## LD 系列旋转给袋包装机

LD-8230/LD-8260/LD-8300/LD-8400



### (一) 常规机械组成

- |            |          |
|------------|----------|
| 1. 打码机     | 6. 电磁阀   |
| 2. PLC控制系统 | 7. 温控仪   |
| 3. 开袋装置    | 8. 真空泵   |
| 4. 振动装置    | 9. 变频器   |
| 5. 气缸      | 10. 输出系统 |

### Option

- |                       |                           |
|-----------------------|---------------------------|
| 1. Code printer       | 6. electromagnetic valve  |
| 2. PLC control system | 7. Temperature controller |
| 3. bag opening device | 8. Vacuum pump            |
| 4. Vibration device   | 9. Inverter               |
| 5. Cylinder           | 10. Output system         |

### (二) 主要性能和结构特点

- 快速更换包装袋的规格, 带宽大小一键自动调节。
- 单轴传动加内凸轮设计, 包装速度快, 运行更加稳定、维修更简单、减少次品率。
- 模块化加热、温控更精准、加热故障可报警提示。
- 先进的设计理念, 降低了包材损耗, 保证了设备运行的稳定性, 延长了设备的运行寿命。
- 操作简单方便, 采用先进的PLC+POD(触摸屏) 电气控制系统, 人机界面友好。
- 机器的包装范围广泛, 可包装液体、膏体、颗粒、粉剂、固体各种可装袋物料, 只需根据不同的计量装置即可。
- 本机适用预制好的包装袋, 包装图案完美、封口品质好, 从而提高了产品的品质与档次。

### Feature

- Rapid change of the specifications of the bag, bag width can be automatically adjusted by one button.
- Single shaft and the CAM design: packaging speed faster; more stable operation; maintenance easier and reduce defective rate.
- Modular heating, temperature control more accurate, heating fault have alarm prompt.
- Advanced design idea, reduce the material loss, ensure the stability of equipment operation, extend the operating life of the equipment.
- Simple and convenient operation, adopts the advanced PLC+POD (touch screen) electric control system and man-machine interface.
- Machine have wide packaging range, it can packaging: liquid, paste, granule, powder, solid various bagging materials only. According to the different material with different metering device.
- Machine use preformed bags & packaging design is perfect & good sealing quality to improve the quality and grade of the product.

### (三) 技术参数 / Specification

机器型号 (Type)	旋转给袋包装机 (Rotary Packing Machine)			
	LD-8230	LD-8260	LD-8300	LD-8400
包装袋型 (Bag Type)	三边封, 四边封袋, 自立袋, 手提袋、壶口袋、拉链袋、复合袋等 3-side, 4 side sealing bag, stand-up bag, handbag, spout bags, zipper bag, compound bag, etc.			
包装尺寸 (Bag Size)	W:80-230mm L:150-380mm	W:140-260mm L:150-380mm	W:180-300mm L:150-430mm	W:270-400mm L:200-500mm
充填范围 (Filling Range)	10-1000g	1500g	2000g	3000g
包装速度 (Packing Speed)	20~60bag/min (其速度由产品自身充填量决定) speed is determined by the product filling quantity	20~50bag/min (其速度由产品自身充填量决定) speed is determined by the product filling quantity	10~40bag/min (其速度由产品自身充填量决定) speed is determined by the product filling quantity	10~25bag/min (其速度由产品自身充填量决定) speed is determined by the product filling quantity
使用电源 (Voltage)	标准AC380V±10%, 三相50HZ; Standard AC380V±10%, three-phase 50HZ;			
总功率 (Total Power)	3.75KW	3.75KW	3.85KW	4.5KW
耗气量 (Air Consumption)	0.4m <sup>3</sup> /min			
外形尺寸 (Dimensions)(L*W*H)	1740*1380*1450mm	1740*1380*1450mm	2460*1830*1460mm	2260*2200*1520mm
机器重量 (Machine Weight)	1300kg	1300kg	1700kg	2000kg

### 工作流程 Work Process

- |                                       |  |
|---------------------------------------|--|
| 1 上袋 (Giving bag)                     | 5 填充, 振动 (可选)<br>filling, vibrate (option)                       |
| 2 打印生产日期 (Coding date)                | 6 填充后产品通过振动积集<br>The filling product is integrated by vibration  |
| 3 开拉链 (opening zipper)                | 7 排气 (选项), 关闭拉链, 热封<br>exhaust (option), closing zipper, sealing |
| 4 充分张开袋子<br>(Open the top and bottom) | 8 整形及输出产品<br>Forming and output                                  |



### (四) 适用范围 / Application

Landpack旋转给袋包装机适用于将粉状、颗粒状或液体灌装入预成型袋并封口, 具体应用说明如下表:

Landpack Rotary packaging machine is applicable for dosing powder, granule or liquid into a premade pouch and sealing, the detail application description as following table:

适用 Application	应用说明 Application Description
适用袋型 Applicable Pouches	复合热封预制成袋, 如扁平袋, 风琴袋, 自立袋, 或自立拉链袋等 Laminate heat sealable premade pouches like flat pouch, gusset pouch, normal stand up pouch, or stand up pouch with zipper etc
适用产品 Applicable Products	配置不同的灌装装置, 可灌装液体、粉末、颗粒或其他不规则固体物料。 Configure with different dosing devices, capable to pack with liquid, powder, granule, or other irregular solidity materials.
适用包装材料 Applicable Packaging Material	OPP/PE、BOPP/OPP/PE、PET/AL等复合热密封包装材料 Laminate Heat sealable packing materials such as OPP/PE, BOPP/OPP/PE, PET/AL etc

### (五) 包装袋型 / Packing Examples



# Granule Rotary Packing Machine

## 颗粒组合称量旋转给袋包装机



序号(Serial Number)	描述(Describe)	功能(Function)
A	Z型提升机 Z type feeding elevator	自动上料到包装机 Auto feeding the products to the machine
B	多头称重下料系统 Multihead electric weigher	自动称重和下料到袋子 Auto weighing and filling the product materials to the bags
C	预制袋包装机 Doypack filling machine	自动送袋, 自动开袋, 灌装, 封口和输出 Auto feeding the ready bags, Auto open the bags, Auto filling, Auto heat sealing and output.
D	重量检测机 Weight detector	重量选别秤检测产品重量, 剔除不符合标准的产品 Weight detector detects the weight of the product and rejects the products that do not meet the standards
E	金属检测机 Metal detector	自动检测和剔除含铁或不锈钢异物的包装 Automatically detect and reject packages containing iron or stainless steel foreign matter
F	圆盘理料机 Rotary collection table	收集成品 Collect finished products

# Powder Rotary Packing Machine

## 粉末计量旋转给袋包装机



序号(Serial Number)	描述(Describe)	功能(Function)
A	螺杆上料机 Auger screws feeding conveyor	自动上料到包装机 Auto feeding the powder to the packing machine
B	螺杆粉剂定量下料系统 Auger screws dosing filling device	定量下料到预制袋 Auto filling the powder to the bags
C	预制袋包装机 Doypack filling machine	自动送袋, 自动开袋, 灌装, 封口和输出 Auto feeding the ready bags, Auto open the bags, Auto filling, Auto heat sealing and output.
D	除尘器 Dust remover	除尘器在灌装时收集粉尘 Dust remover to collect duty while filling



# Liquid Rotary Packing Machine

## 液体计量旋转给袋包装机



序列号 (Serial Number)	描述 (Describe)	功能 (Function)
A	储料斗 Storage hopper	液体料斗储存产品 Liquid hopper storage products
B	液体泵计量 Liquid pump metering	液体泵计量产品重量 定量下料到预制袋 Liquid pump measures product weight and filling the products to the bags
C	预制袋包装机 Doypack filling machine	自动送袋, 自动开袋, 灌装, 封口和输出 Auto feeding the ready bags, Auto open the bags, Auto filling, Auto heat sealing and output.

### >> 包装样袋 / Sample



# Rotary Vacuum Doypack Filling Machine

## 给袋机真空包装机

LDZK-200/240/260



### >> 技术参数 / Specification

机器型号 (Type)	给袋机真空包装机 (Rotary Vacuum Doypack Filling Machine)		
	LDZK-200	LDZK-240	LDZK-260
包装袋型 (Bag Type)	三边封, 四边封袋, 自立袋, 手提袋, 拉链袋, 复合袋等 3-side, 4 side sealing bag, stand-up bag, handbag, zipper bag, compound bag, etc.		
包装尺寸 (Bag Size)	W: 120-200mm L:150-300mm	W: 120-240mm L:150-320mm	W: 120-260mm L:150-360mm
充填范围 (Filling Range)	20-1000g (取决于产品类型) (speed is determined by the product filling quantity)		
包装速度 (Packing Speed)	30-50包/分钟 (其速度由产品自身充填量决定) 25-40包/分钟 (拉链袋) 30-50bag/min (speed is determined by the product filling quantity) 25-40 bags/min (for zipper pouch)		
计量平均精度 (Average Precision)	<±1%		
压缩空气消耗量 (Compressed air consumption)	≥0.8立方米/分 (压缩空气由用户自行提供) ≥0.8 m³/min (Compressed air provided by the user)		
外形尺寸 (Dimensions)	2650x1650x1700mm(L*W*H)		

### 工作流程 Work Process



## Other Supporting Equipments

### 配套设备



Z型提升机  
Z type buckets feeding elevator



皮带上料机  
Belt feeding conveyor



螺杆提升机  
Auger screws feeding conveyor



真空上料机  
Vacuum feeder

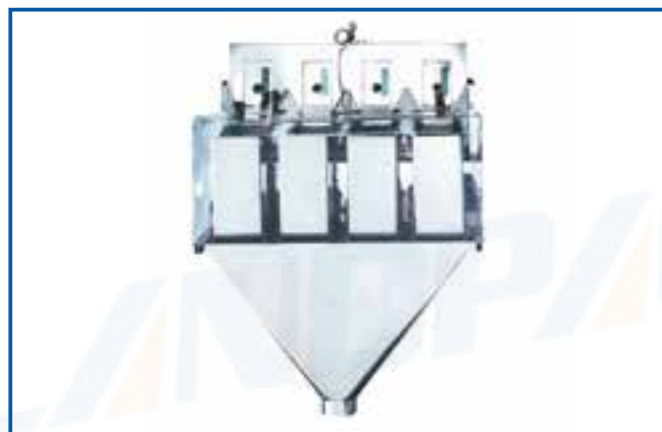

线性电子秤  
Linear type electrical weigher



多头组合秤  
Multi-head electrical weigher

## Other Supporting Equipments

### 配套设备



螺杆粉剂头  
Auger screws dosing filling hopper device



粉末搅拌罐  
Mixer tank



喷码机  
Inkjet coding printer



干燥剂投包机  
Desiccant bagging machine



重量检测机  
Weight detector



金属检测机  
Metal detector