

让世界的包装因揽德更美好

Make the world's packaging be better because LANDPACK

LANDPACK

揽德包装机械

MULTI LINE PACKING MACHINE CATALOG

多列机画册



中文官网



English Web



佛山市揽德包装机械有限公司

FOSHAN LAND PACKAGING MACHINERY CO.,LTD

地址：广东省佛山市南海区狮山镇下柏第一工业区吉祥路8号智展科技产业园

Add: Zhisheng Technology Industrial Park, No. 8 Jixiang Road, Xiabai First Industrial Zone,
Shishan Town, Nanhai District, Foshan, Guangdong, China

Tel: 0757-81807872 Fax: 0757-81807758

网址: www.landpack.cn Web: www.landpack.com

E-mail: yang@landpacking.com

佛山市揽德包装机械有限公司

FOSHAN LAND PACKAGING MACHINERY CO.,LTD



About LandPack

关于揽德

Foshan Land Packaging Machinery Co., Ltd. is located in Foshan, Guangdong Province, within a one-hour drive from Guangzhou Airport and just 20 minutes from Foshan High-Speed Railway Station. Established in 2017, the company is a high-tech enterprise integrating R&D, manufacturing, sales, and service. With a modern factory covering 30,000 square meters, Landpack is equipped with a team of senior engineers, installation and commissioning technicians, and marketing & after-sales service professionals. With over 130 employees, we provide customers with professional products and reliable service support.

Since its establishment, Landpack has been dedicated to the R&D and manufacturing of vertical form fill seal machines, filling machines, premade pouch packaging machines, multi lane packaging machines, flow pack machines, and feeding and packaging lines. Our products are widely applied in industries such as snacks food and health supplements, pet food, daily chemical products, fresh produce, sauces, and powders, offering customized and complete packaging solutions for enterprises.

Our products have obtained lots of national patent certificates, ISO9001 Quality Management System certification, as well as CE, TUV, SGS, and FDA approvals. They are exported to more than 100 countries and regions worldwide, receiving wide recognition and praise from customers.

At Landpack, we are committed to continuously refining and optimizing our products to deliver intelligent packaging equipment that is efficient, stable, safe, and beautiful packaging—striving to go beyond expectations and make the world a better place with Landpack Packaging.

佛山市揽德包装机械有限公司坐落于广东省佛山市，位于广州机场一小时，佛山动车站二十分钟交通圈。公司成立于2017年，是一家集研发、制造、销售及服务于一体的高新技术企业，配备三万平米现代化厂房，拥有骨干工程师，安装调试技术团队和营销与售后技术服务团队，员工规模达130人，为客户提供专业的产品和服务保障。

我司自成立以来，专注于研发和制造立式包装机，灌装机，给袋式包装机，多列机和枕式机、理料线包装设备，产品广泛用于休闲零食食品、食品保健品，宠物食品，日用化工用品，果蔬生鲜，酱料和粉剂等行业，致力为企业客户定制和提供整体包装解决方案。

产品已获多个国家技术专利证书，并通过ISO9001质量管理体系认证，获欧盟CE，TUV，SGS，FDA认证。产品远销海外一百多个国家和地区，受到企业客户广泛好评和认可。

揽德人将持续深耕和优化产品，为客户提供高效，稳定，安全，包装美观的智能包装设备，并力求超越，让世界因揽德包装而更美好。



Development History of LandPack

揽德发展历程

2017-2018

Established 成立

LANDPACK brand was established, independently developed and manufactured vertical machines and pillow machines, obtained ISO9001 quality management system certification, EU CE, TUV, SGS, FDA certification, and its products were exported to more than 60 countries and regions, and has been widely praised and recognized by corporate customers.

LANDPACK揽德品牌建立，自主研发生产制造立式机和枕式机，获ISO9001质量管理体系认证，欧盟CE，TUV，SGS，FDA认证，产品远销六十多个国家和地区，受到企业客户广泛好评和认可。

2019-2024

Expansion 壮大

The Landpack's factory has expanded to 10,000 square meters, establishing dedicated departments for premade pouch machines, multilane packaging machines, and filling machines, along with a supporting machining center. The team has grown with the addition of senior engineers, experienced installation and commissioning technicians, as well as marketing and after-sales professionals, bringing the workforce to 140 employees. Our sales team has actively promoted the LANDPACK brand by participating in major exhibitions in Germany, Thailand, and across China, including Shanghai and Qingdao. Drawing on deep expertise in packaging solutions for snacks, pet food, daily chemical products, health supplements, and pharmaceuticals, the company delivers over 180 customized full-line packaging solutions annually, achieving a turnover of 80 million RMB.

厂房规模扩大至一万平方米，建立给袋机产品部门，多列机产品部门和灌装机产品部门，并建立配套机加工中心，新增多名骨干工程，资深安装调试技术员，营销和售后技术人员，员工规模达140人，继销售团队参加海外德国展、泰国展，及国内上海、青岛等多个展会进行品牌营销。结合公司团队深耕积累休闲零食食品，宠物食品，日用化工，保健品药品行业包装技术方案经验。一年为客户定制提供180多个整线包装方案，公司营业额达8000万。

2025-NOW

Development 发展

After thorough preparation, the company officially relocated from its 10,000m² old factory to a new 30,000m² modern plant. The expanded space accommodates more production lines and R&D areas, not only meeting the growing demand for capacity but also providing employees with an enhanced working environment. This relocation marks more than a physical upgrade—it represents a new milestone for high-quality development, empowering LANDPACK to serve customers with stronger capabilities and move forward with greater momentum.

历经筹备，公司正式从1万方旧厂房，乔迁至3万方新址！新厂房空间扩容，可承载更多生产线与研发区域，既解产能增长之需，也为员工提供更优环境。这不仅是物理空间的升级，更是公司迈向高质量发展的新起点，未来将以更强实力服务客户、聚力前行。





Technical strength 技术实力



CE 认证



CE 认证



CE 认证



Rohs证书



TUV 认证

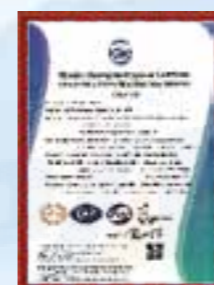

ISO 认证



SGS 认证



专利证书



专利证书



专利证书



专利证书



专利证书



专利证书



专利证书



专利证书

Sales Marketing And Technical Services

营销和技术服务



200+
Industry packaging solution cases
every year

100%
After-sales technical service support



LandPack Exhibitions

揽德展会





目/录

CONTENTS

四边封多列包装机 Multi Lane Four Side Sealing Bag Packing Machine

四边封多列液体包装机 P01

Multi Lane Four Side Sealing Bag Liquid Packing Machine

四边封多列颗粒包装机 P02

Multi Lane Four Side Sealing Bag Granule Packing Machine

四边封多列粉末包装机 P03

Multi Lane Four Side Sealing Bag Powder Packing Machine

背封多列包装机 Multi-Lane Stick Bag Packing Machine

背封液体多列包装机 P04

Multi-Lane Stick Bag Liquid Packing Machine

背封颗粒多列包装机 P05

Multi-Lane Stick Bag Granule Packing Machine

背封粉末多列包装机 P06

Multi-Lane Stick Bag Powder Packing Machine

三边封液体多列包装机 Multi Lane Three Side Sealing Bag Liquid Packing Machine P07

液体异型袋多列包装机 Liquid Shaped Bag Multi-Lane Packing Machine P08

大容量粉末多列包装机 High Capacity Powder Sachets Packing Machine P09

粉末棒袋包装机生产线 Powder Stick Bag Packing Machine Line P10

全自动多列机+装盒机包装线 Fully Automacti Multi Lane+Box Packing Machine Line P11

全自动多列机+装盒机+打码机包装线 Fully Automacti Multi Lane+Box Packing+Inject Printer Machine Line P13

Multi Lane Four Side Sealing Bag Liquid Packing Machine 四边封多列液体包装机

LDFS-480L/720L/960/1200L



样品/Sample



特点/Characteristic

1	适用于液体类包装: 酱, 蜂蜜, 油, 果冻, 洗发水, 面霜等;	Suit for Liquid: Sauce, Honey, Oil, Jelly, Shampoo, Facial Cream, etc;
2	伺服控制拉膜, 运行稳定顺畅;	Servo Driven System for Pulling Film Working, More Stable and Smoothly;
3	单独的活塞泵计量, 精度高;	Separate Piston Pump Measuring and Filling System, with High Accuracy;
4	打码清晰, 封口美观, 切角完整;	Clear Coding, Beautiful Sealing and Smooth Cutting;

技术参数/Technical parameter

型号(Model)	LDFS-480L	LDFS-720L	LDFS-960L
列数(Track Number)	4~6列(Track)	4~10列(Track)	4~12列(Track)
计量方式(Filing Method)	1.活塞泵 / Piston pump; 2.蠕动泵 / Peristaltic pump		
包装速度(Charity)	每分钟最大40切; Max.40 cycle/min		
制袋尺寸(Bag Size)	L:45-120mm; W:38-60mm	L:45-120mm; W:38-90mm	L:45-120mm; W:38-120mm
膜宽膜厚(Fim W&D)	Max.480mm; 0.07-0.1mm	Max.720mm; 0.07-0.1mm	Max.960mm; 0.07-0.1mm
封口形式(Sealing Type)	四边封 / Four sides sealing		
气压功率(Air & Power)	0.8mpa; 0.8m ³ /min; 2.8kw	0.8mpa; 0.8m ³ /min; 4.1kw	0.8mpa; 0.8m ³ /min; 5.5kw
尺寸重量(DIM & WT)	950*1470*1750mm; 300kg	1153*1654*1750mm; 400kg	1415*1686*2130mm; 500kg

Multi Lane Four Side Sealing Bag Granule Packing Machine 四边封多列颗粒包装机

LDFS-480G/720G/960G



样品/Sample



特点/Characteristic

1	适用于颗粒状: 盐, 砂糖, 咖啡, 调味料, 洗衣粉等;	Suit for Granule: Salt, Sugar, Coffee, Spice, Washing powder etc;
2	伺服控制拉膜, 运行稳定顺畅;	Servo Driven System for Pulling Film Working, More Stable and Smoothly;
3	单独的螺杆计量伺服控制, 精度高;	Separate Servo Driven System for Each Auger Screw, with High Accuracy;
4	打码清晰, 封口美观, 切角完整;	Clear Coding, Beautiful Sealing and Smooth Cutting;

技术参数/Technical parameter

型号(Model)	LDFS-480G	LDFS-720G	LDFS-960G
列数(Track Number)	4~6列(Track)	4~10列(Track)	4~12列(Track)
计量方式(Filing Method)	量杯 / Volumetric cup		
包装速度(Charity)	每分钟最大35切; Max.35 cycle/min		
制袋尺寸(Bag Size)	L:45-120mm; W:38-60mm	L:45-120mm; W:38-90mm	L:45-120mm; W:38-120mm
膜宽膜厚(Fim W&D)	Max.480mm; 0.07-0.1mm	Max.720mm; 0.07-0.1mm	Max.960mm; 0.07-0.1mm
封口形式(Sealing Type)	四边封 / Four sides sealing		
气压功率(Air & Power)	0.8mpa; 0.8m ³ /min; 2.8kw	0.8mpa; 0.8m ³ /min; 4.1kw	0.8mpa; 0.8m ³ /min; 5.5kw
尺寸重量(DIM & WT)	950*1470*1750mm; 300kg	1153*1654*1750mm; 400kg	1415*1686*2130mm; 500kg

Multi Lane Four Side Sealing Bag Powder Packing Machine

四边封多列粉体包装机

LDFS-480D/720D/960D



样品/Sample



特点/Characteristic

1	适用于粉状: 面粉, 蛋白粉, 奶粉, 葡萄糖粉, 药粉等;	Suit for Powder : Flour, Albumen powder, Milk powder, Medical powder;
2	伺服控制拉膜,运行稳定顺畅;	Servo Driven System for Pulling Film Working, More Stable and Smoothly;
3	真空泵上料,更卫生;	Vacuum Feeder is More Hygienic Conveying of Materials;
4	打码清晰,封口美观,切角完整;	Clear Coding, Beautiful Sealing and Smooth Cutting;

技术参数/Technical parameter

型号(Model)	LDFS-480D	LDFS-720D	LDFS-960D
列数(Track Number)	4~6列(Track)	4~10列(Track)	4~12列(Track)
计量方式(Filing Method)	螺杆 / Auger metering		
包装速度(Charity)	每分钟最大40切; Max.40 cycle/min		
制袋尺寸(Bag Size)	L:45-120mm; W:38-60mm	L:45-120mm; W:38-90mm	L:45-120mm; W:38-120mm
膜宽膜厚(Fim W&D)	Max.480mm; 0.07-0.1mm	Max.720mm; 0.07-0.1mm	Max.960mm; 0.07-0.1mm
封口形式(Sealing Type)	四边封 / Four sides sealing		
气压功率(Air & Power)	0.8 MPA0.8m ³ /min; 2.8kw	0.8 MPA0.8m ³ /min; 4.1kw	0.8mpa; 0.8m ³ /min; 5.5kw
尺寸重量(DIM & WT)	950*1470*1750mm; 300kg	1153*1654*1750mm; 400kg	1415*1686*2130mm; 500kg

Multi Lane Stick Bag Liquid Packing Machine

背封液体多列包装机

LDBK-280L/560L



样品/Sample



特点/Characteristic

1	适用于液体类包装: 酱, 蜂蜜, 油, 果冻, 洗发水, 面霜等;	Suit for Granule : Sauce, Honey, Oil, Jelly, Shampoo, Facial Cream, etc;
2	伺服控制拉膜,运行稳定顺畅;	Servo Driven System for Pulling Film Working, More Stable and Smoothly;
3	活塞泵计量,伺服电机控制快接头;	Piston Pump Metering Servo Motor Control Fast Connect for Clamp Style

技术参数/Technical parameter

型号(Model)	LDBK-280L	LDBK-560L
列数(Track Number)	4~6列(Lane)	8~12列(Lane)
计量方式(Filing Method)	1.活塞泵 / Piston pump; 2.蠕动泵 / Peristaltic pump	
包装速度(Charity)	每分钟最大35切; Max.35 cycle/min	
制袋尺寸(Bag Size)	L:50-180mm; W:17-30mm	L:50-180mm; W:17-30mm
膜宽膜厚(Fim W&D)	Max.280mm; 0.07-0.10mm	Max.560mm; 0.07-0.10mm
封口形式(Sealing Type)	背封Backsealing/Stick bag	
切口形式(Cuting Type)	1.平口切 / Straight cutting; 2.锯齿切 / Zig zag cutting; 3.圆角切 / Round cutting	
气压功率(Air & Power)	0.8mpa; 0.8m ³ /min; 3.5kw	0.8mpa; 0.8m ³ /min; 5.5kw
尺寸重量(DIM & WT)	1385*918*2005mm; 350kg	1685*1300*2005mm; 550kg

Multi Lane Stick Bag Granule Packing Machine

背封颗粒多列包装机

LDBK-280G/560G



样品/Sample



特点/Characteristic

1	适用于粉状: 盐, 砂糖, 咖啡, 调味料, 洗衣粉等;	Suit for Granule: Salt, Sugar, Coffee, Spice, Washing powder etc;
2	伺服控制拉膜, 运行稳定顺畅;	Servo Driven System for Pulling Film Working, More Stable and Smoothly;
3	单独的螺杆计量伺服控制, 精度高;	Separate Servo Driven System for Each Auger Screw, with High Accuracy;

技术参数/Technical parameter

型号(Model)	LDBK-280G	LDBK-560G
列数(Track Number)	4~6列(Lane)	8~12列(Lane)
计量方式(Filing Method)	量杯 / Volumetric cup	
包装速度(Charity)	每分钟最大35切; Max.35 cycle/min	
制袋尺寸(Bag Size)	L:50-180mm; W:17-30mm	L:50-180mm; W:17-30mm
膜宽膜厚(Fim W&D)	Max.280mm; 0.07-0.10mm	Max.560mm; 0.07-0.10mm
封口形式(Sealing Type)	背封Backsealing/Stick bag	
切口形式(Cuting Type)	1.平口切 / Straight cutting; 2.锯齿切 / Zig zag cutting; 3.圆角切 / Round cutting	
气压功率(Air & Power)	0.8mpa; 0.8m ³ /min; 3.5kw	0.8mpa; 0.8m ³ /min; 5.5kw
尺寸重量(DIM & WT)	1385*918*2005mm; 350kg	1685*1300*2005mm; 550kg

Multi Lane Stick Bag Powder Packing Machine

背封粉末多列包装机

LDBK-280D/560D



样品/Sample



特点/Characteristic

1	适用于粉状: 面粉, 蛋白粉, 奶粉, 葡萄糖粉, 药粉等;	Suit for Powder : Flour, Albumen powder, Milk powder, Medical powder;
2	伺服控制拉膜, 运行稳定顺畅;	Servo Driven System for Pulling Film Working, More Stable and Smoothly;
3	真空上料机自动上料, 自动停止上料;	Vacuum Pump Feeding Powder Automatically,

技术参数/Technical parameter

型号(Model)	LDBK-280D	LDBK-560D
列数(Track Number)	4~6列(Lane)	8~12列(Lane)
计量方式(Filing Method)	螺杆 / Auger metering	
包装速度(Charity)	每分钟最大35切; Max.35 cycle/min	
制袋尺寸(Bag Size)	L:50-180mm; W:17-30mm	L:50-180mm; W:17-30mm
膜宽膜厚(Fim W&D)	Max.280mm; 0.07-0.10mm	Max.560mm; 0.07-0.10mm
封口形式(Sealing Type)	背封Backsealing/Stick bag	
切口形式(Cuting Type)	1.平口切 / Straight cutting; 2.锯齿切 / Zig zag cutting; 3.圆角切 / Round cutting	
气压功率(Air & Power)	0.8mpa; 0.8m ³ /min; 3.5kw	0.8mpa; 0.8m ³ /min; 5.5kw
尺寸重量(DIM & WT)	1385*918*2005mm; 350kg	1685*1300*2005mm; 550kg

Multi Lane Three Side Sealing Bag Liquid Packing Machine

三边封液体多列包装机

LDTs-280L/560L



▶ 样品/Sample



▶ 特点/Characteristic

1	适用于液体类包装：酱，蜂蜜，油，果冻，洗发水，面霜等；	Suit for Granule : Sauce, Honey, Oil, Jelly, Shampoo, Facial Cream, etc;
2	伺服控制拉膜,运行稳定顺畅；	Servo Driven System for Pulling Film Working, More Stable and Smoothly;
3	活塞泵计量,伺服电机控制快接头；	Piston Pump Metering Servo Motor Control Fast Connect for Clamp Style

▶ 技术参数/Technical parameter

型号(Model)	LDTs-280L	LDTs-560L
列数(Track Number)	4~6列(Lane)	8~12列(Lane)
计量方式(Filing Method)	1. 活塞泵 / Piston pump; 2. 蠕动泵 / Peristaltic pump	
包装速度(Charity)	每分钟最大35切; Max.35 cycle/min	
制袋尺寸(Bag Size)	L:50-180mm; W:17-30mm	L:50-180mm; W:17-30mm
膜宽膜厚(Fim W&D)	Max.280mm; 0.07-0.10mm	Max.560mm; 0.07-0.10mm
封口形式(Sealing Type)	三边封/Three side sealing	
切口形式(Cuting Type)	1. 平口切 / Straight cutting; 2. 锯齿切 / Zig zag cutting; 3. 圆角切 / Round cutting	
气压功率(Air & Power)	0.8mpa; 0.8m ³ /min; 3.5kw	0.8mpa; 0.8m ³ /min; 5.5kw
尺寸重量(DIM & WT)	1385*918*2005mm; 350kg	1685*1300*2005mm; 550kg

Liquid Shaped Bag Multi-Lane Packing Machine

液体异型袋多列包装机

LDLS-620L



▶ 样品/Sample



▶ 特点/Characteristic

1	适用于液体类包装：酱，蜂蜜，油，果冻，洗发水，面霜等；	Suit for Granule : Sauce, Honey, Oil, Jelly, Shampoo, Facial Cream, etc;
2	陶瓷泵计量,容易调节,精准计量；	Ceramic Pump Filling, Easy Measuring, High Accuracy;
3	定制化模具,可以根据客户个性化形状设计定制模具；	Custom-ized Mode, Can Design Base on Customers' personalized Idea;

▶ 技术参数/Technical parameter

型号(Model)	LDLS-620L
列数(Track number)	2~4列(Track)
计量方式(Filling Method)	1. 活塞泵 / Piston pump; 2. 蠕动泵 / Peristaltic pump
包装速度(Charity)	每分钟大概20-30切; 20-30 cycle/min
制袋尺寸(Bag Size)	L:50-170mm; W:70-230mm
膜宽膜厚(Film W&D)	Max.500mm; 0.07-0.10mm
封口形式(Sealing Type)	异型袋 / Irregular shape bag
气压功率(Air & Power)	220V/380V 50HZ, 5.0kw
耗气量(Air Consumption)	0.8mpa; 0.8m ³ /min
尺寸重量(DIM & WT)	2600*1350*2350mm, 800kg

High Capacity Powder Sachets Packing Machine

大容量粉末多列包装机

LDBK-1100D



样品/Sample



特点/Characteristic

1	适用于粉状:面粉,蛋白粉,奶粉,葡萄糖粉,药粉等;	Suit for Powder : Flour, Albumen powder, Milk powder, Medical powder;
2	多通道灌装和包装粉末,实现高产能生产和高品牌产品质量;	Multi-lane filling and packing the powder for high capacity production and high brand product quality;
3	易于与包装线自动连接,扩大和升级生产;	Easy to automatic connect working with boxes packing line to expanding and upgrading the production;

技术参数/Technical parameter

型号(Model)	LDBK-1100D	
列数(Track Number)	2~6列(Track)	
计量方式(Filing Method)	螺杆 / Auger metering	
包装速度(Charity)	每分钟最大30切; Max.30 cycle/min	
制袋尺寸(Bag Size)	L:50-130mm; W:50-100mm	
膜宽膜厚(Fim W&D)	Max.1100mm; 0.07-0.10mm	
封口形式(Sealing Type)	背封Backsealing / Stick bag	
切口形式(Cuting Type)	1.平口切 / Straight cutting; 2.锯齿切 / Zig zag cutting; 3.圆角切 / Round cutting	
气压功率(Air & Power)	0.8mpa; 0.8m ³ /min; 5.0kw	
尺寸重量(DIM & WT)	5500*3375*3550mm,900kg	

Powder Stick Bag Packing Machine Line

粉末棒袋包装机生产线



样品/Sample



二维尺寸图/ Drawing

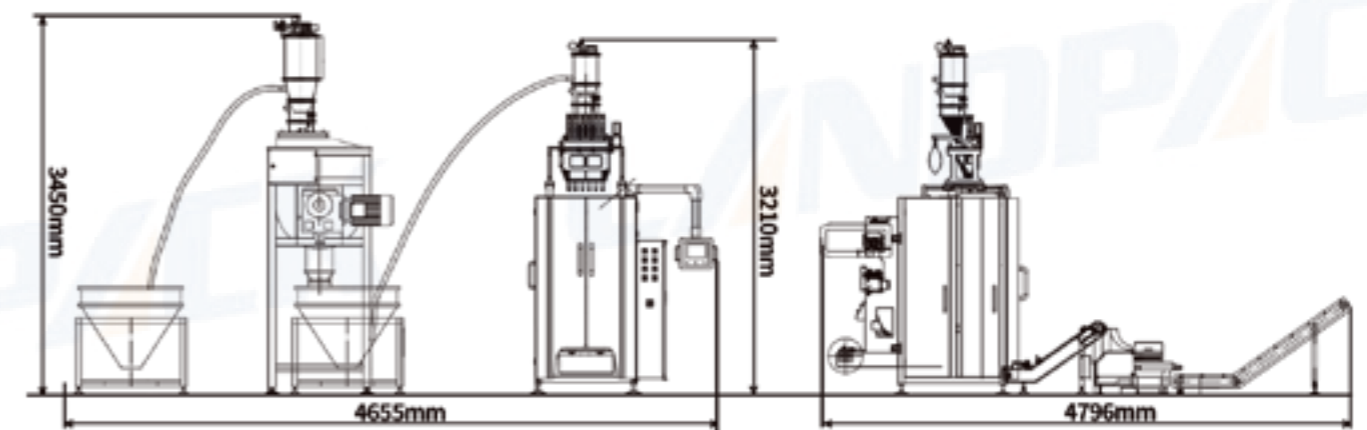

特点/Characteristic

1	全自动整线粉末混合,上料,灌装下料,包装到重检剔除,无需人工触碰粉末,包装过程安全,省人工。	Full automatic packing line including storage, powder mixing, feeding, filling and packing, sealing and output then weight check and reject without people touch for safety production and save the labor;
2	定制螺杆下料系统,下料稳定,封口干净牢固,包装精准度高;	Customized auger screws filling system to filling the powder stably, the sealing is clean and firmly with high accuracy;
3	输出端自动对接重检剔除,包装生产过程高效省力,保证产品交付合格率;	Auto output to the weight checker to checking the weight to make sure the qualified delivery rate of products with high efficiency and save labor;

Fully Automacti Multi Lane + Box Packing Machine Line

全自动多列机+装盒机包装线



配套机组	①粉末多列包装机+②激光打码机+③理料输送带+④装盒机
Machine Name	① Powder Multi Lanes Packing Machine + ② Laser Coding Machine + ③ Bag Sorting Conveyor + ④ Boxing Machine

二维尺寸图/ Drawing

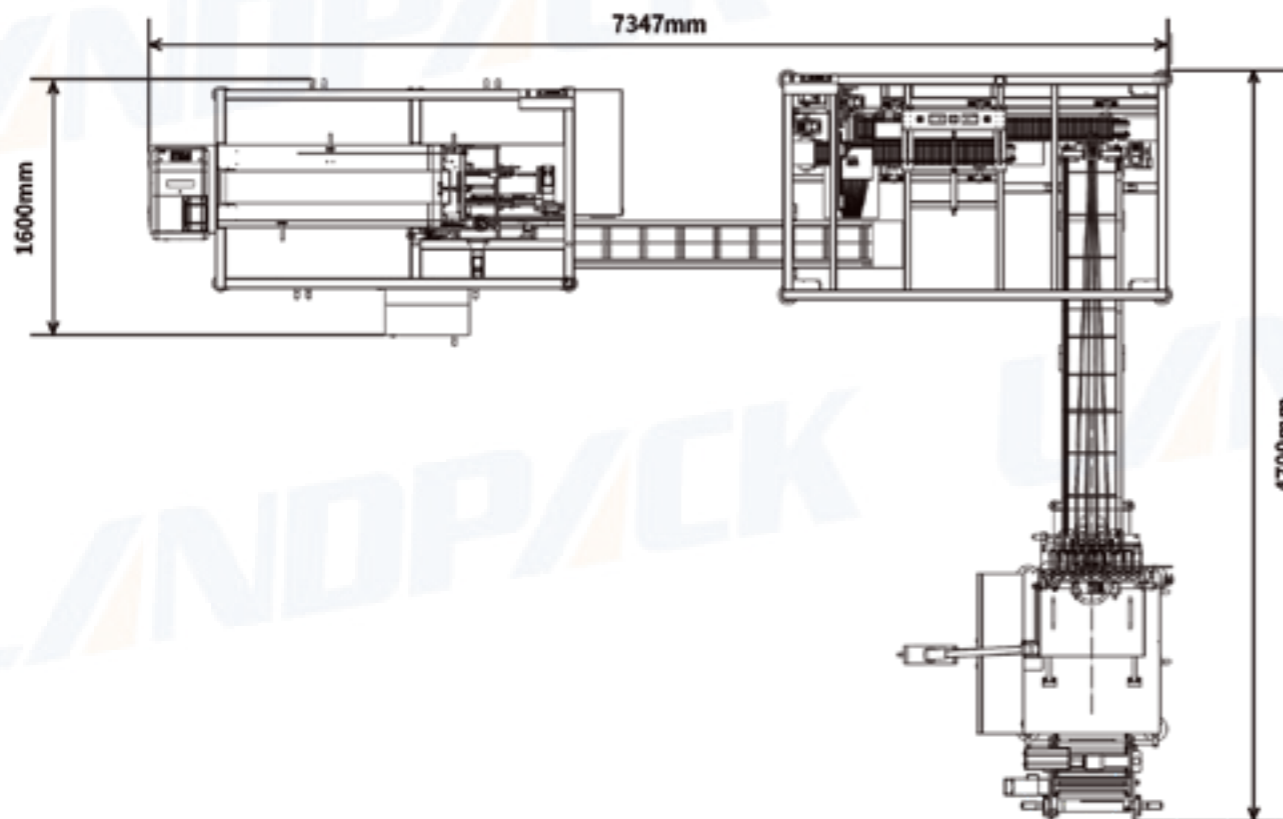

样品/Sample



特点/Characteristic

1	适用于粉状:面粉,蛋白粉,奶粉,葡萄糖粉,药粉等;	Suit for Powder : Flour, Albumen powder, Milk powder, Medical powder;
2	真空上料机将物料输送到储物罐中;	Vacuum feeder to transport material into material tank;
3	量杯计量,伺服控制,精度高;	Volumetric cup as dosing system;
4	棒状小袋将通过斜坡传送带运送到分拣机;	Stick sachets would be transported to the sorting machine by slope conveyor belt
5	通过分拣机将预期的数量小袋推到装盒机的传送带上;	Expected sachet quantity would be pushed to the conveyor belt of boxing machine by Transitional structure;
6	伺服装盒包装机;	Servo boxing packing machine;
7	用激光打印机在纸箱上打印信息;	Printing info on carton box by Laser printer;

技术参数/Technical parameter

多列包装机 (Mutiland Stick Packing Machine)	
型号(Model)	LDBK-280D
列数(Track number)	4~6列(Lane)
计量方式(Filing Method)	螺杆 / Auger metering
包装速度(Packing Speed)	每分钟最大35切;Max.35 cycle/min
制袋尺寸(Bag Size)	L:50-180mm; W:17-30mm
膜宽膜厚(Fim W&D)	Max.280mm; 0.07-0.10mm

装盒机 (Bag in Box Packing System)		
型号(Model)	LDDS-100	LDDS-120
包装速度(Packing Speed)	40~60 boxes/min	30~50 boxes/min
箱尺寸 (Box Size)	L:60~220mm; W:20~125mm; H:15~60mm	L:80~250mm; W:100~160mm; H:40~90mm
耗气量(Air Consumption)	≥0.6 mpa, 20 m³/h	
气压功率(Air & Power)	220V/380V, 50HZ; 4.5kw	220V/380V, 50HZ; 5.5kw
尺寸重量(DIM & WT)	3425*1390*1771mm; 1200kg	3450*1450*1800mm; 1600kg

Fully Automacti Multi Lane + Box Packing + Inject Printer Machine Line 全自动多列机+装盒机+打码机包装线



配套机组	①粉末多列包装机+②理料输送带+③说明书发卡机+④装盒机+⑤打码机
Machine Name	① Powder Multi Lanes Packing Machine + ② Bag Sorting Conveyor + ③ Manual Feeding + ④ Boxing Machine + ⑤ Inject Printer

二维尺寸图/ Drawing

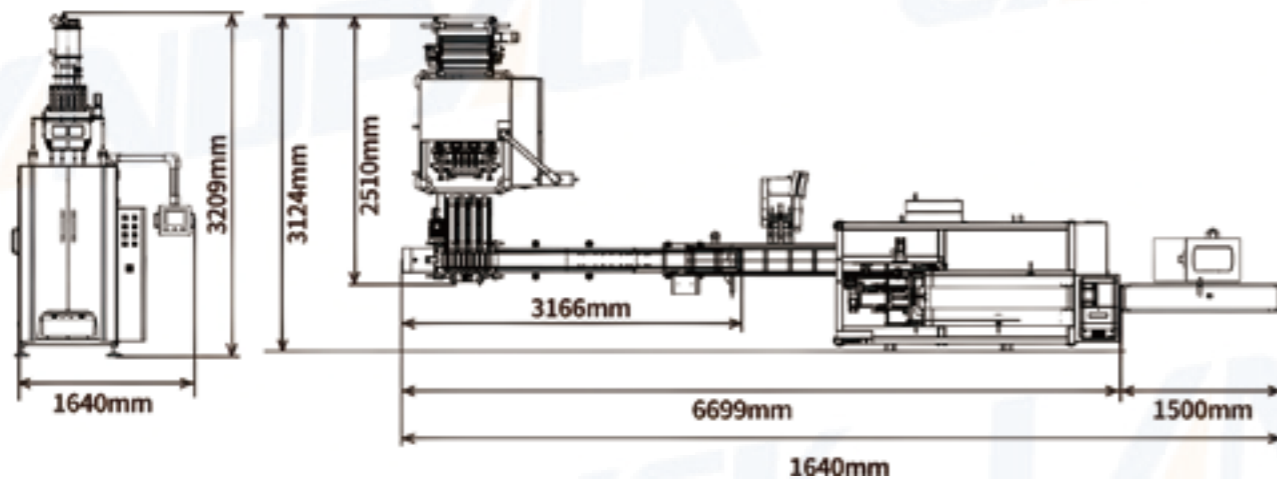

样品/Sample



特点/Characteristic

1	适用于粉状:面粉,蛋白粉,奶粉,葡萄糖粉,药粉等;	Suit for Powder : Flour, Albumen powder, Milk powder, Medical powder;
2	真空上料机将物料输送到储物罐中;	Vacuum feeder to transport material into material tank;
3	量杯计量,伺服控制,精度高;	Volumetric cup as dosing system;
4	伺服点数功能灵活设置不同的条包数量;	With servo motor control counting conveyor flexible for the stick bag quantity;
5	棒状小袋将通过斜坡输送带运送到分拣机;	Stick sachets would be transported to the sorting machine by slope conveyor belt
6	通过分拣机将预期的数量小袋推到装盒机的传送带上;	Expected sachet quantity would be pushed to the conveyor belt of boxing machine by Transitional structure;
7	伺服发说明书功能;	Servor motor for control the user manual feeder;
8	伺服装盒包装机;	Servo boxing packing machine;
9	用激光打印机在纸箱上打印信息;	Printing info on carton box by Laser printer;
10	机器由PLC系统控制,可简单灵活地使用和操控机器;	The whole set of machine is controlled by PLC controlling system, so it is very easy for the worker to operate the machine well;

技术参数/Technical parameter

多列包装机 (Mutiland Stick Packing Machine)	
型号(Model)	LDBK-280D
列数(Track number)	4~6列(Lane)
计量方式(Filing Method)	螺杆 / Auger metering
包装速度(Packing Speed)	每分钟最大35切;Max.35 cycle/min
制袋尺寸(Bag Size)	L:50-180mm; W:17-30mm
膜宽膜厚(Fim W&D)	Max.280mm; 0.07-0.10mm

装盒机 (Bag in Box Packing System)		
型号(Model)	LDDS-100	LDDS-120
包装速度(Packing Speed)	40~60 boxes/min	30~50 boxes/min
箱尺寸 (Box Size)	L:60~220mm; W:20~125mm; H:15~60mm	L:80~250mm; W:100~160mm; H:40~90mm
耗气量(Air Consumption)	≥0.6 mpa, 20 m ³ /h	
气压功率(Air & Power)	220V/380V, 50HZ; 4.5kw	220V/380V, 50HZ; 5.5kw
尺寸重量(DIM & WT)	3425*1390*1771mm; 1200kg	3450*1450*1800mm; 1600kg